

TM 10-4330-235-13&P

TECHNICAL MANUAL

OPERATOR, UNIT, AND DIRECT SUPPORT
MAINTENANCE MANUAL INCLUDING
REPAIR PARTS AND SPECIAL TOOLS LIST

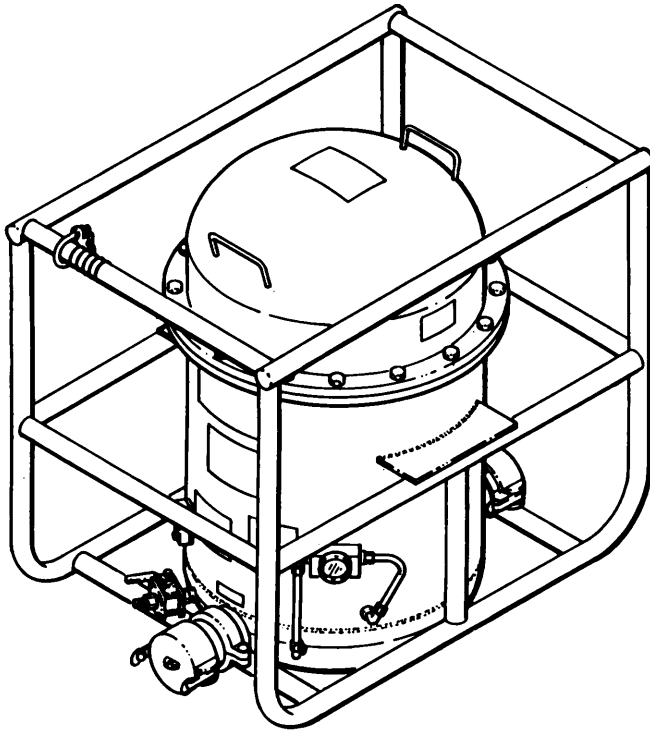

OPERATING INSTRUCTIONS
PAGE 2-1

OPERATOR PREVENTIVE
MAINTENANCE CHECKS AND
SERVICES PAGE 2-3

OPERATOR MAINTENANCE
PAGE 3-1

UNIT MAINTENANCE PAGE 4-1

UNIT TROUBLESHOOTING
PAGE 4-2

DIRECT SUPPORT MAINTENANCE
PAGE 5-1

**FILTER SEPARATOR, LIQUID FUEL;
FRAME MOUNTED,
350 GPM CAPACITY
(NSN 4330-00-177-8485)**

DISTRIBUTION STATEMENT A: Approved for public release; distribution is unlimited.

HEADQUARTERS, DEPARTMENT OF THE ARMY

31 MARCH 1993

WARNINGS

Give particular attention to specific WARNINGS and CAUTIONS throughout this manual. DEATH or serious injury may result if personnel fail to observe safety precautions.

Dry cleaning solvent, PD-680A, used to clean parts is potentially dangerous to personnel and property. Avoid repeated or prolonged skin contact. Do not use near open flame or excessive heat. Flash point of solvent is 100 - 138°F (38 - 60° C).

Do not smoke or use open flame within 50 feet (15.34 meters) of filter/separator.

Make sure fire extinguishers and fire fighting equipment are available in the immediate area. Be extremely careful when using fire extinguisher in an enclosed area. Provide adequate ventilation.

Do not drain fuel from the unit on the ground. Drain fuel into a container that can be closed, otherwise a fire hazard or environmental contamination could result.

Use protective equipment to prevent skin and eye contact with fuel.

Use rubber fuel resistant gloves when replacing filter elements due to toxic effects of some fuel additives.

Dispose of filter elements in accordance with local policy.

A static discharge could ignite the fuel or cause an explosion of the fuel vapor. Do not operate the filter/separator until it has been connected to suitable ground.

For artificial respiration, refer to FM 21-11.

TECHNICAL MANUAL
 NO. 10-4330-235-13&P

HEADQUARTERS
 DEPARTMENT OF THE ARMY
 WASHINGTON D.C., 31 March 1993

TECHNICAL MANUAL

**Operator, Unit and Direct Support Maintenance Manual
 Including Repair Parts and Special Tools List**

For

**Filter Separator, Liquid Fuel; Frame Mounted,
 350 GPM Capacity
 (NSN 4330-00-177-8485)**

Current as of 5 February 1993

REPORTING ERRORS AND RECOMMENDING IMPROVEMENTS

You can help improve this manual. If you find any mistakes or if you know of a way to improve the procedures, please let us know. Mail your letter, DA Form 2028 (Recommended Changes to Publications and Blank Forms), or DA Form 2028-2 located in the back of this manual direct to: Commander, US Army Aviation and Troop Command, ATTN: AMSAT-I-MTS, 4300 Goodfellow Blvd., St. Louis, MO 63120-1798. A reply will be furnished directly to you.

DISTRIBUTION STATEMENT A: Approved for public release; distribution is unlimited.

TABLE OF CONTENTS

	PAGE	ILLUS/ FIGURE
HOW TO USE THIS MANUAL		
CHAPTER 1 INTRODUCTION	1-1	
Section I. General Information	1-1	
Section II. Equipment Description	1-2	
Section III. Principles of Operation	1-4	
CHAPTER 2 Operating INSTRUCTIONS	2-1	
Section I. Description and Use of Operator's Controls and Indicators	2-2	
Section II. Preventive Maintenance Checks and Services	2-3	
Section III. Operation Under Usual Conditions	2-6	
Section IV. Operation Under Unusual Conditions	2-10	
CHAPTER 3 OPERATOR Maintenance	3-1	
Section I. Lubrication Instructions	3-1	
Section II. Troubleshooting Procedures	3-1	
Section III. Maintenance Procedures	3-2	

	PAGE	ILLUS/ FIGURE
CHAPTER 4	UNIT MAINTENANCE	4-1
Section I.	Repair Parts and Special tools List	4-1
Section II.	Service Upon Receipt	4-1
Section III.	Preventive Maintenance Checks and Services	4-1
Section IV.	Troubleshooting	4-2
Section V.	Maintenance Procedures	4-4
CHAPTER 5	DIRECT SUPPORT MAINTENANCE	5-1
Section I.	Repair Parts and Special Tools LIST	5-1
Section II.	Troubleshooting	5-1
Section III.	Maintenance Procedures	5-2
APPENDIX A	REFERENCES	A-1
APPENDIX B	MAINTENANCE ALLOCATION CHART	B-1
APPENDIX C	REPAIR PARTS AND SPECIAL TOOLS LIST	C-1
Section I.	Introduction	C-1
Section II.	Repair Parts List	C-1-1
Group 01	Filter Separator	C-1-1
	Cover, Canisters and Elements	C-1-1
	Gages, Valves and Lines	C-2-1
	Tank and Frame	C-3-1
Group 02	Water Detector Adapter	C-4-1
	Water Detector Kit	C-4-1
Section III.	Special Tools List	C-5-1
Section IV.	Cross Reference Indexes	C-I-1
	National Stock Number	C-I-1
	Part Number index	C-I-2
	Figure and Item Number Index	C-I-4
APPENDIX D	COMPONENTS END ITEM AND BASIC ISSUE ITEMS LIST	D-1
APPENDIX E	ADDITIONAL AUTHORIZED LIST	E-1
APPENDIX F	EXPENDABLE/DURABLE SUPPLIES AND MATERIALS LIST	F-1
APPENDIX G	TORQUE LIMITS	G-1
APPENDIX H	MANDATORY REPLACEMENT PARTS LIST	H-1
APPENDIX I	MANUFACTURED ITEMS LIST	I-1

HOW TO USE THIS MANUAL

Spend a few minutes looking through this manual. It has a new look that may be different from the manuals you've been using. You'll find the new look is a lot easier to use, and you can find what you're looking for a lot faster.

Each chapter begins with an index that lists each paragraph or section in the chapter. Or you can look for the information you want in the alphabetical subject index at the back of this manual.

We got rid of as many words as we could and put in lots of illustrations to show just about everything you'll be doing to maintain your equipment.

The text is keyed to the illustration with callout numbers (sometimes words). The callout numbers are in parentheses in the text.

So, HOW DO YOU USE THIS MANUAL?

Like This:

1. Suppose the differential pressure gage indicates in red and you want to troubleshoot the unit.
2. Look at the cover and you'll see index boxes near the right-hand edge with subject titles in them. You'll find "UNIT TROUBLESHOOTING PAGE 4-2". You can skip over to page 4-2.

OR

3. Bend the pages a bit and look at the edges. You'll see black bars on some of the pages that are lined up with the index boxes on the cover.
4. If you put your thumbnail on the black bar that is lined up with the box on the cover for UNIT TROUBLESHOOTING and open the manual, you'll be on page 4-2.
5. On page 4-2, you'll find Section IV, TROUBLESHOOTING.
6. Turn to page 4-3 and find the symptom "DIFFERENTIAL PRESSURE GAGE INDICATION IS IN RED".
7. As you do the tests and corrective actions in the order listed, you will get to replace elements and clean canister.
8. Turn to paragraph 4-6 and look at the procedure. The "INITIAL SETUP" section tells you what tools, materials, and parts are needed to do this task. It also tells you anything you must do before starting this task and it gives general warnings about hazards that can exist while you do this task.
9. The procedure itself has a picture to show you where to look and what to look at, plus the steps you will do to perform the task.
10. Notice the numbered arrows. These are the callout numbers. As you read each step, we tell you where to look by including the callout number (in parentheses) after the name of each thing we call out.
11. Do the procedure, then check to see if you have corrected the fault symptom.

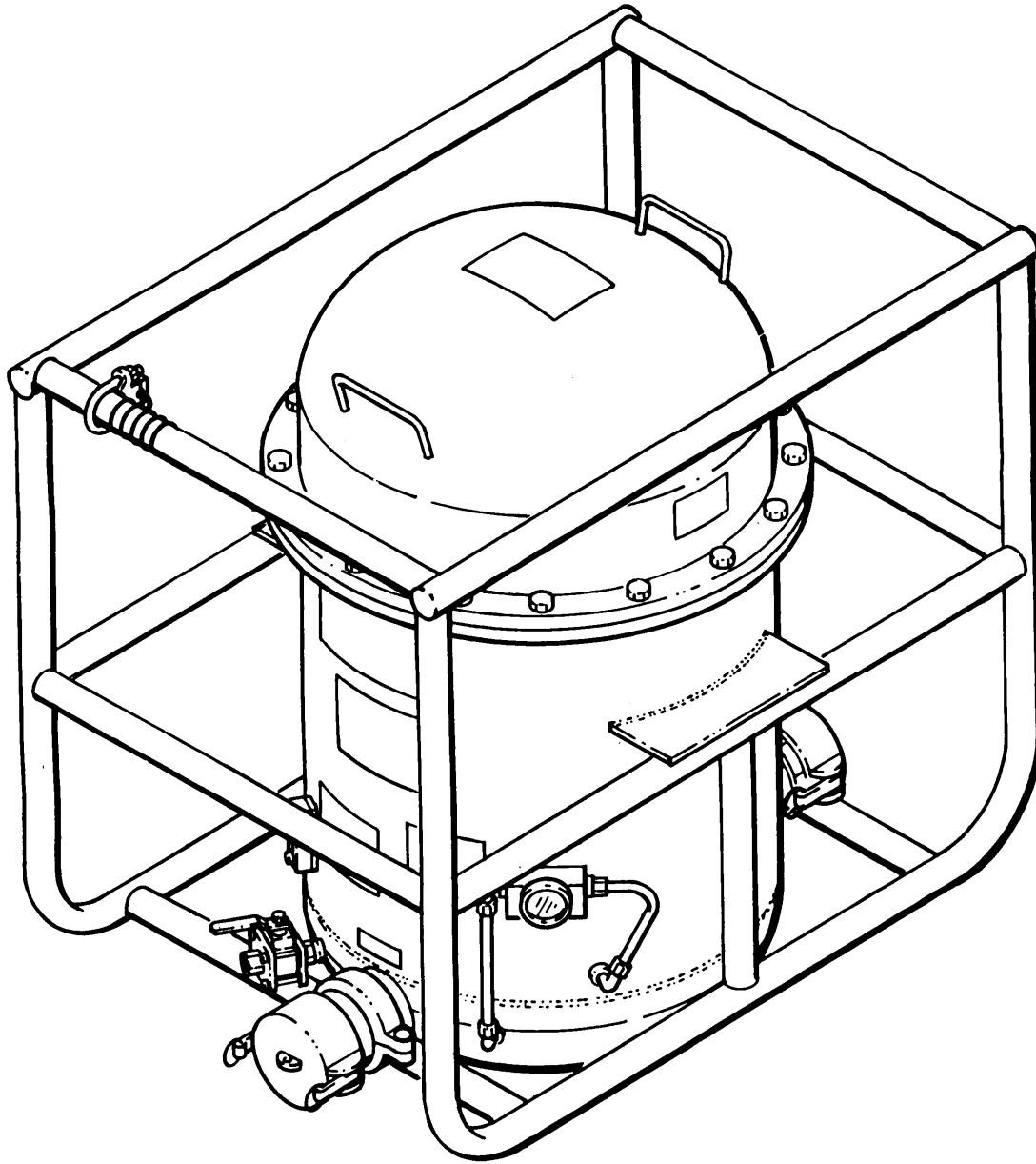

CHAPTER 1

INTRODUCTION

Section I. General information**1-1. SCOPE**

- a. Type of Manual: Operator, Unit and Direct Support Maintenance Including Repair Parts and Special Tools List.
- b. Equipment Name: 350 GPM, Frame Mounted, Liquid Fuel Filter/Separator, Model 13217E9320.
- c. Purpose of Equipment: Removal of water and solid contaminants from petroleum fuels.

1-2 MAINTENANCE FORMS AND RECORDS

Department of the Army forms and procedures used for equipment maintenance will be those prescribed by (as applicable) DA Pam 738-750, The Army Maintenance Management System - Aviation (TAMMS-A); or AR 700-138, Army Logistics Readiness and Sustainability.

1-3. CORROSION PREVENTION AND CONTROL

- a. Corrosion Prevention and Control (CPC) of Army materiel is a continuing concern. It is important that any corrosion problems with this item be reported so that the problem can be corrected and improvements can be made to prevent the problem in future items.
- b. While corrosion is typically associated with rusting of metals, it can also include deterioration of other materials, such as rubber and plastic. Unusual cracking, softening, swelling or breaking of the materials may be corrosion problems.
- c. If a corrosion problem is identified, it can be reported using Standard Form 368, Product Quality Deficiency Report. Use of key words such as "rust", "deterioration", "corrosion", or "cracking" will insure that the information is identified as a CPC problem. The form should be submitted to the address specified in DA Pam 738-750.

1-4. DESTRUCTION OF ARMY MATERIEL TO PREVENT ENEMY USE

Refer to TM750-244-3 for procedure for destruction of equipment to prevent enemy use.

1-5. REPORTING EQUIPMENT IMPROVEMENT RECOMMENDATION (EIR)

If your Filter/Separator needs improvement, let us know. Send us an EIR. You, the user, are the only one who can tell us what you don't like about your equipment. Let us know why you don't like the design or performance. Put it on an SF 368 (Product Quality Deficiency Report). Mail it to us at Commander, U. S. Army Aviation and Troop Support Command; ATTN: AMSAT-I-MDO; 4300 Goodfellow Blvd.; St. Louis, MO 63120-1798. We will send you a reply.

Section II. Equipment Description

1-6. EQUIPMENT CHARACTERISTICS, CAPABILITIES AND FEATURES

a. Characteristics.

- (1) The 350 GPM (gallons per minute) filter/separator consists of a vessel with a removable cover, 18 canisters and filter elements, a differential pressure indicator, a water level sight gage, a manual water drain valve and a manual air vent valve. The inlet and outlet connections are cam lock type quick disconnect couplings.
- (2) An adapter is supplied with the filter/separator to allow attachment of a fuel contamination test kit to determine if the unit is filtering properly.

b. Capabilities and Features.

- (1) Frame mounted, two stage, vertical-type unit,
- (2) All weather operational.
- (3) Fully transportable.

1-7 LOCATION AND DESCRIPTION OF MAJOR COMPONENTS

The following paragraphs contain a functional description of the major components of the filter/separator. The location and appearance of the major components are illustrated. The numbers following the nomenclature of the major component correspond to the index numbers in the illustration.

- a. SIGHT GAGE (1). Indicates the level of water in the vessel.
- b. DRAIN VALVE (2). Ball-type valve for manually draining water from vessel.
- c. PRESSURE GAGE (3). Indicates the differential between inlet and outlet pressures to determine filter element condition.
- d. AIR VENT VALVE (4). Manually operated valve to release air from the vessel.
- e. FRAME AND VESSEL (5). Provides a housing for the 18 canisters and filter elements. The tubular rectangular frame is designed to facilitate handling during transport and provide a stable base for the filter/separator during operation.
- f. ADAPTER ASSEMBLY (6). This adapter is connected at the filter/separator outlet coupling. The adapter contains a sampling probe which extends into the fuel flow. A Water Detector Kit may be connected to the probe for fuel sampling.

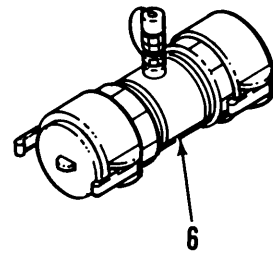
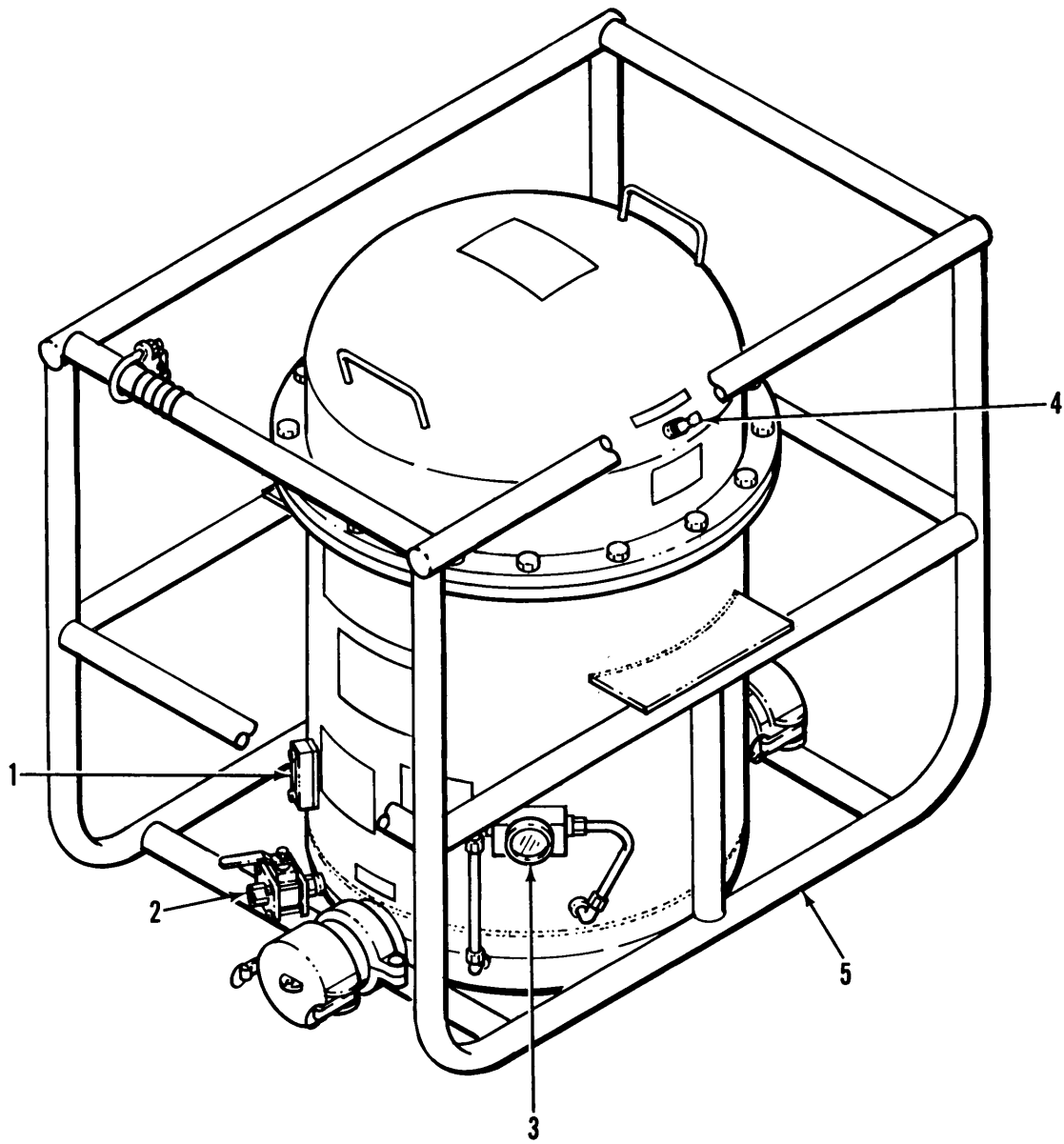

1-8. EQUIPMENT DATA

a. Identification.

Specification	MIL-F-52666
Design Activity Code	97403
Model	13217E9320
NSN	4330-00-177-8485
Manufacturer	Beta Systems, Inc
Capacity	350 GPM
Working Pressure (max.)	150 psi

b. Dimensions and Weight.

Length	47 in.
Width	33.25 in.
Height	40.5 in.
Weight	375 lb.

c. Differential Pressure Indicator.

Specification Control No.	13219E9749-1
Manufacturer	Orange Research, Inc.
Part No.	1201PG-2-2
Maximum Pressure	35 psid
Tolerance	± 2 psi

d. Filter Element.

Specification	MIL-F-52308
NSN	4330-00-983-0998
Quantity	18

Section III. Principles of Operation

1-9. PRINCIPLES OF OPERATION.

Fuel under pressure enters the filter/separator's inlet connection, then passes through perforated center tubes of the filter elements toward the outside of the elements. A pleated paper tube material in the elements remove solid contaminants then fiberglass outer layers coalesce any entrained water into large droplets as they reach the outside of the elements. The fuel then flows through the teflon coated screen inside the canisters where the water droplets are stopped and pulled downward by gravity to the sump for subsequent draining. The clean fuel then flows into the top of the outlet tube and out the outlet coupling of the filter/separator.

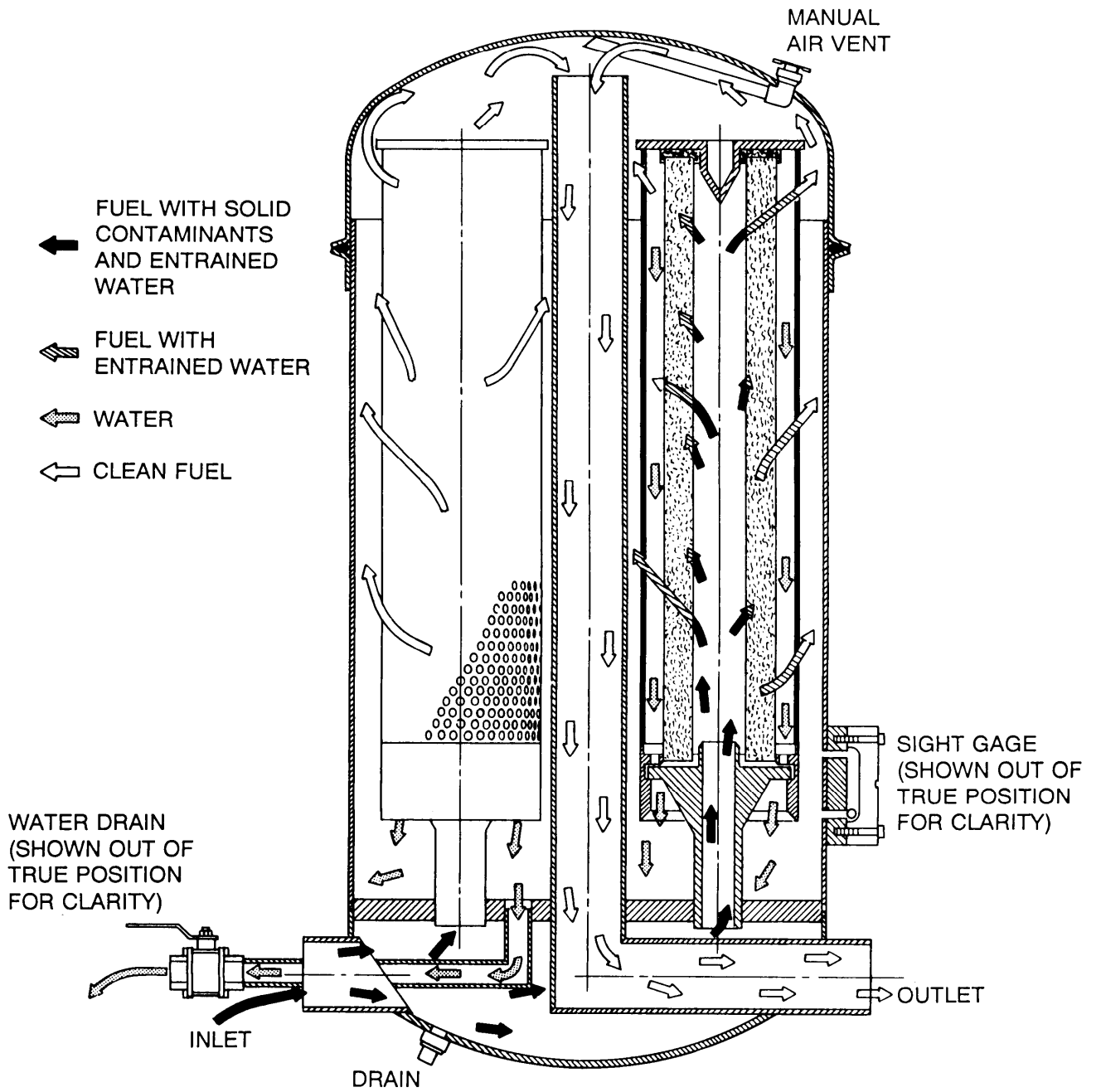

CHAPTER 2

OPERATING INSTRUCTIONS

Section I.	Description and Use of Operator Controls and Indicators	2-2
	2-1 Controls and Indicators	2-2
Section II.	Preventive Maintenance Checks and Services	2-3
	2-2 Introduction	2-3
	2-3 Operator's PMCS Table	2-3
Section III.	Operation Under Usual Conditions	2-6
	2-4 Preparation for Operation	2-6
	2-5 Operation	2-9
	2-6 Shutdown	2-9
Section IV.	Operation Under Unusual Conditions	2-10
	2-7 Operating in Unusual Conditions	2-10
	2-8 Location of Data and Identification Plates	2-11

Section I. Description and Use of Operator's Controls and Indicators

2-1 CONTROLS AND INDICATORS

The controls and indicators for operation of the filter/separator are illustrated and described in Table 2-1.

Table 2-1. Controls and indicators

KEY	CONTROL OR INDICATOR	FUNCTION
1	Sight Gage	Indicates the level of water in the filter/separator.
2	Water Drain Valve	Drains water from the filter/separator.
3	Differential Pressure Gage	Indicates the difference between inlet and outlet pressure.
4	Pressure Vent Valve	Releases air displaced by incoming fuel.

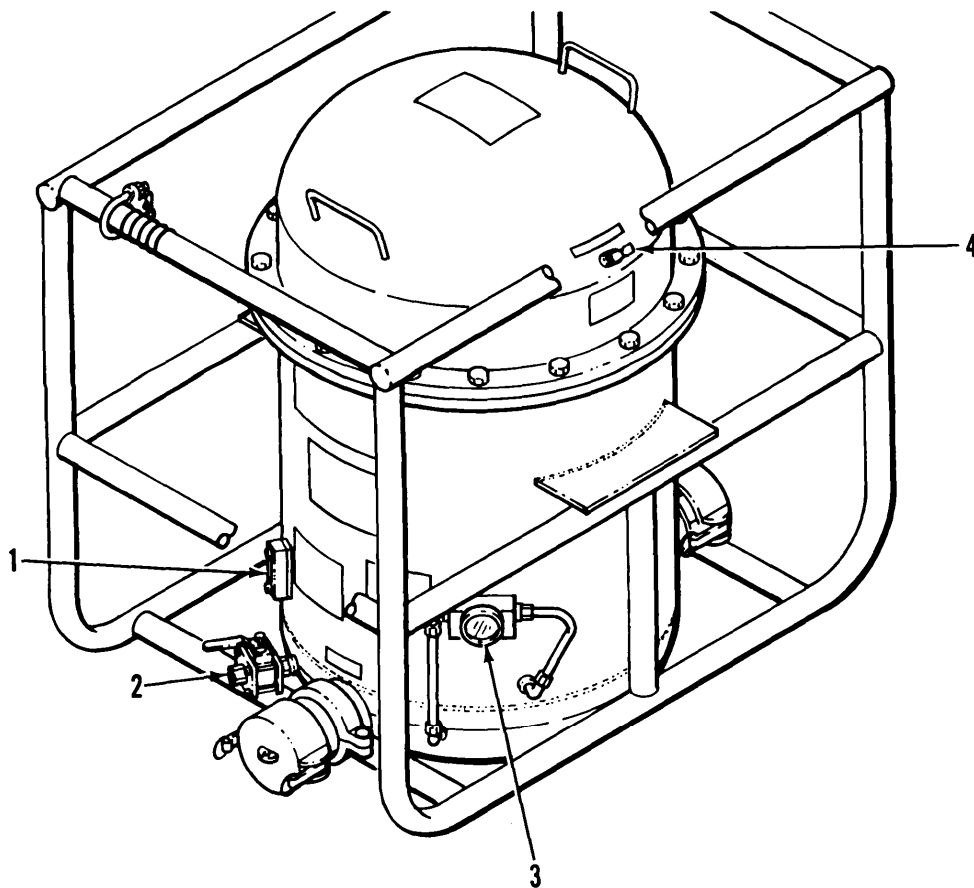

Section II. Preventive Maintenance Checks and Services (PMCS)

2-2. INTRODUCTION

- a. General. A PMCS table, Table 2-2, has been provided so you can keep your equipment in good operating condition and ready for its primary mission.
- b. Warnings and Cautions. Always observe the WARNINGS and CAUTIONS appearing in the PMCS table. Warnings and cautions appear before the procedure to which they apply. You must observe these WARNINGS and CAUTIONS to prevent serious injury to yourself and others or prevent damage to your equipment.

2-3. OPERATOR'S PMCS TABLE

a. Explanation of Columns.

- (1) Item No. Numbers in this column are for reference. When completing DA Form 2404 (Equipment Inspection and Maintenance Worksheet), include the item number for the check/service indicating a fault. Item numbers also appear in the order that you must do checks and services for the intervals listed.
- (2) Interval. This column tells you when you must do the procedure in the procedure column. BEFORE procedures must be done before you operate or use the equipment for its intended mission. DURING procedures must be done during the time you are operating or using the equipment for its intended mission. AFTER procedures must be done immediately after you have operated or used the equipment.
- (3) Item to Check/Service. This column lists the name of the item to be checked or serviced.
- (4) Procedure. This column gives the procedure you must do to check or service the item listed in the Check/Service column to know if the equipment is ready or available for its intended mission or for operation. You must do the procedure at the time stated in the interval column.
- (5) Not Fully Mission Capable If. Information in this column tells you what faults will keep your equipment from being capable of performing its primary mission. If you make check and service procedures that show faults listed in this column, do not operate the equipment. Follow standard operating procedures for maintaining the equipment or reporting equipment failure.

- b. Other Table Entries. Be sure to observe all special information and notes that appear in your table.

Table 2-2. Preventive Maintenance Checks and Services for
350 GPM Filter/Separator

Item	Interval	Item to Check/Service	Procedure	Not Fully Mission Capable If:
1	BEFORE	Diff. Pressure Gage	Inspect for secure mounting, loose connections or damage.	Gage is damaged. Valve is inoperable.
2	BEFORE	Tube Assemblies	Inspect for kinks, breaks and loose fittings.	
3	BEFORE	Sight Gage	Inspect for cracked gage body. See that mounting screws are tight.	
4	BEFORE	Pressure Vent Valve	Press valve to check operation.	
5	BEFORE	Drain Valve	See that handle is CLOSED.	
WARNING				
Failure to properly ground filter/separator prior to operation could allow a static discharge (spark) which could ignite fuel or cause an explosion of fuel vapor.				
6	BEFORE	Ground Rod	Inspect that ground cable is secure to rod.	Cable not secure.
7	BEFORE	Plates	Inspect that all instruction and warning plates are legible.	
8	BEFORE	Tank and Frame	Inspect for damage, loose or missing hardware.	Hardware is missing.
9	BEFORE	Adapter and Probe	Inspect that adapter and probe are secure.	
10	DURING	Diff. Pressure Gage	Inspect gage indication. If yellow, see table 3-1.	Indication is in red.
11	DURING	Sight Gage	Check water level. Drain when ball reaches mark.	

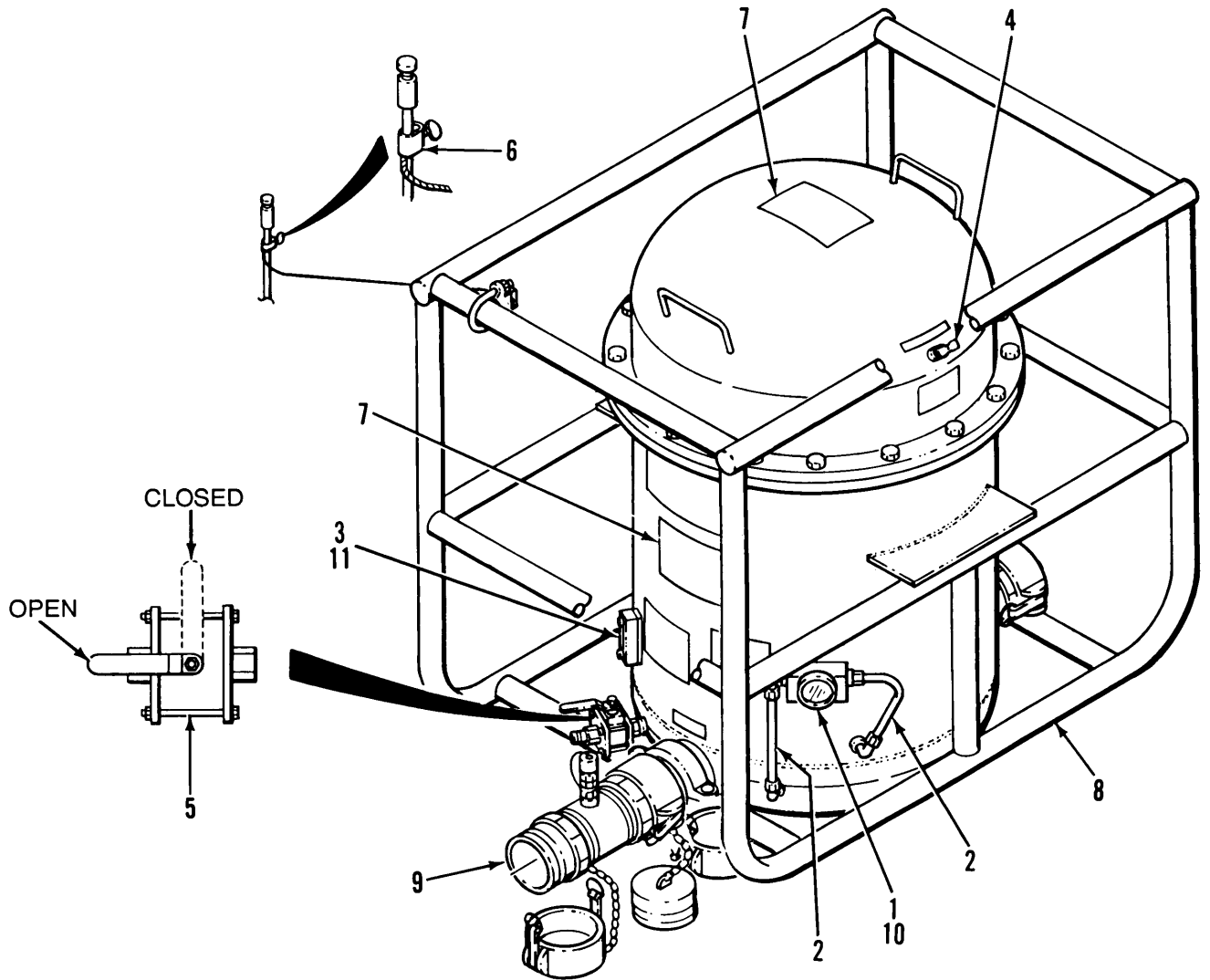

Section III. Operation Under Usual Conditions

2-4. PREPARATION FOR OPERATION

CAUTION

Filter/separator must be installed in the upright position only or unit will not properly filter fuel.

- a. Installation. Place the filter/separator on a level site in an upright position.

WARNING

Failure to properly ground filter/separator prior to operation could allow a static discharge (spark) which could ignite fuel or cause an explosion of fuel vapor.

- b. Grounding. The ground rod must be driven into ground three to eight feet.

- (1) Install the drive bolt (1) into a ground rod section (2) and drive the section into ground.
- (2) Remove drive bolt (1) from section (2) and install it into another section (3). Screw section (3) into section (2) and drive sections into ground.
- (3) Remove drive bolt (1) from section (3) and install in top section (4). Screw section (4) into section (3) and drive sections into ground.
- (4) Insert ground wire (5) into clamp (6) and tighten thumbscrew (7).

NOTE

In the event that ground cannot be sufficiently penetrated, bury ground rod in a horizontal trench not less than eight feet in length and at least eight inches beneath the surface.

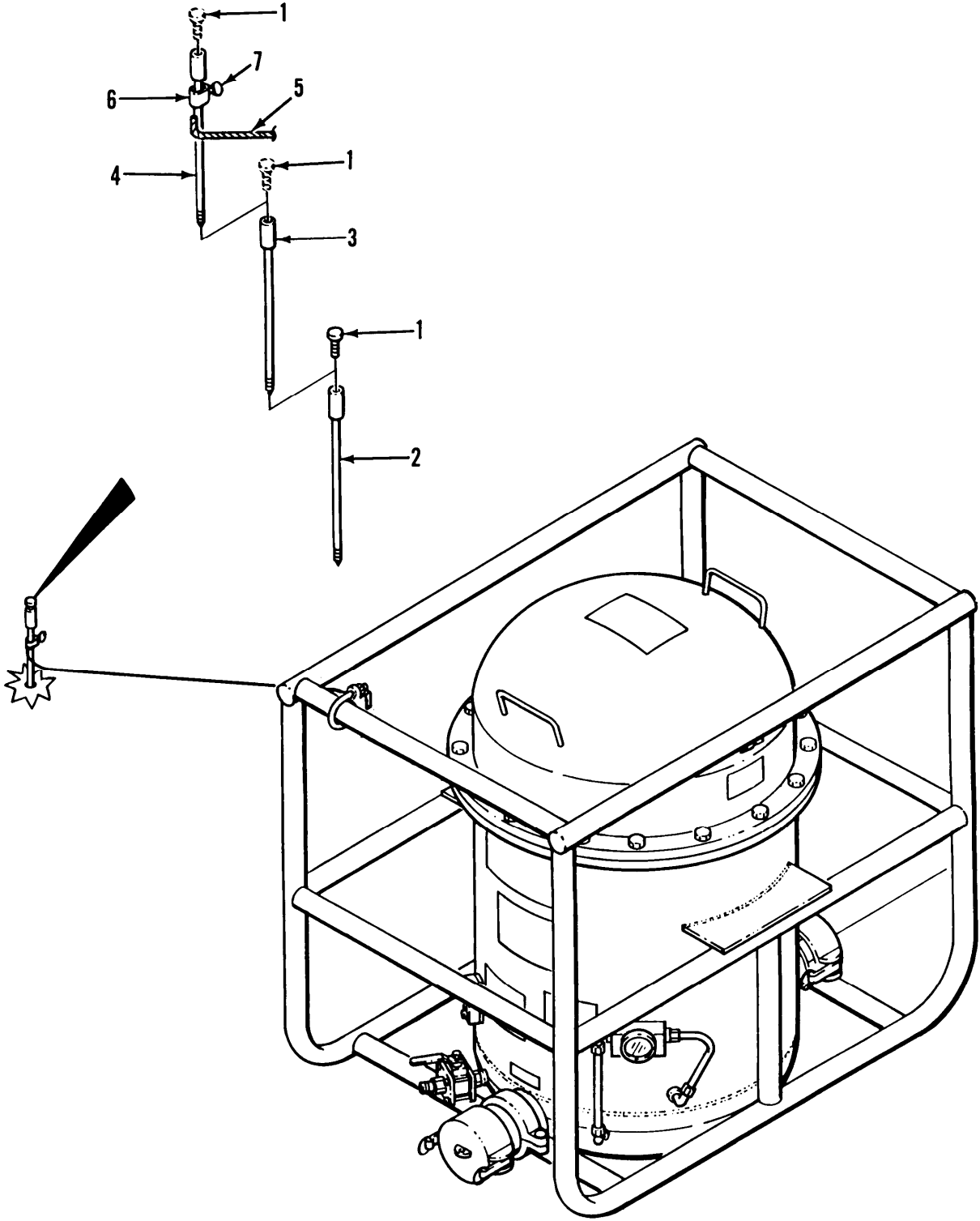

c. Connections.

NOTE

Make certain that the quick disconnect cams on female coupling halves are pulled all the way so that male coupling halves can be securely seated. Check to see that gaskets are installed in each female coupling half.

- (1) Remove dust plug (1) from filter/separator inlet coupling (2) and attach four inch hose (3) with male coupling to inlet coupling (2). Drive cams home to secure coupling.
- (2) Remove dust cap (4) from filter/separator outlet coupling (5).
- (3) Make sure that the bevel (6) on the sampling probe (7) is pointed in the direction of female coupling (8). Remove dust plug (9) from adapter (10).
- (4) Attach adapter (10) to filter/separator outlet coupling (5). Drive cams home to secure coupling.
- (5) Remove dust cap (11) from adapter (10) and attach four inch hose (12) with female coupling. Drive cams home to secure coupling.

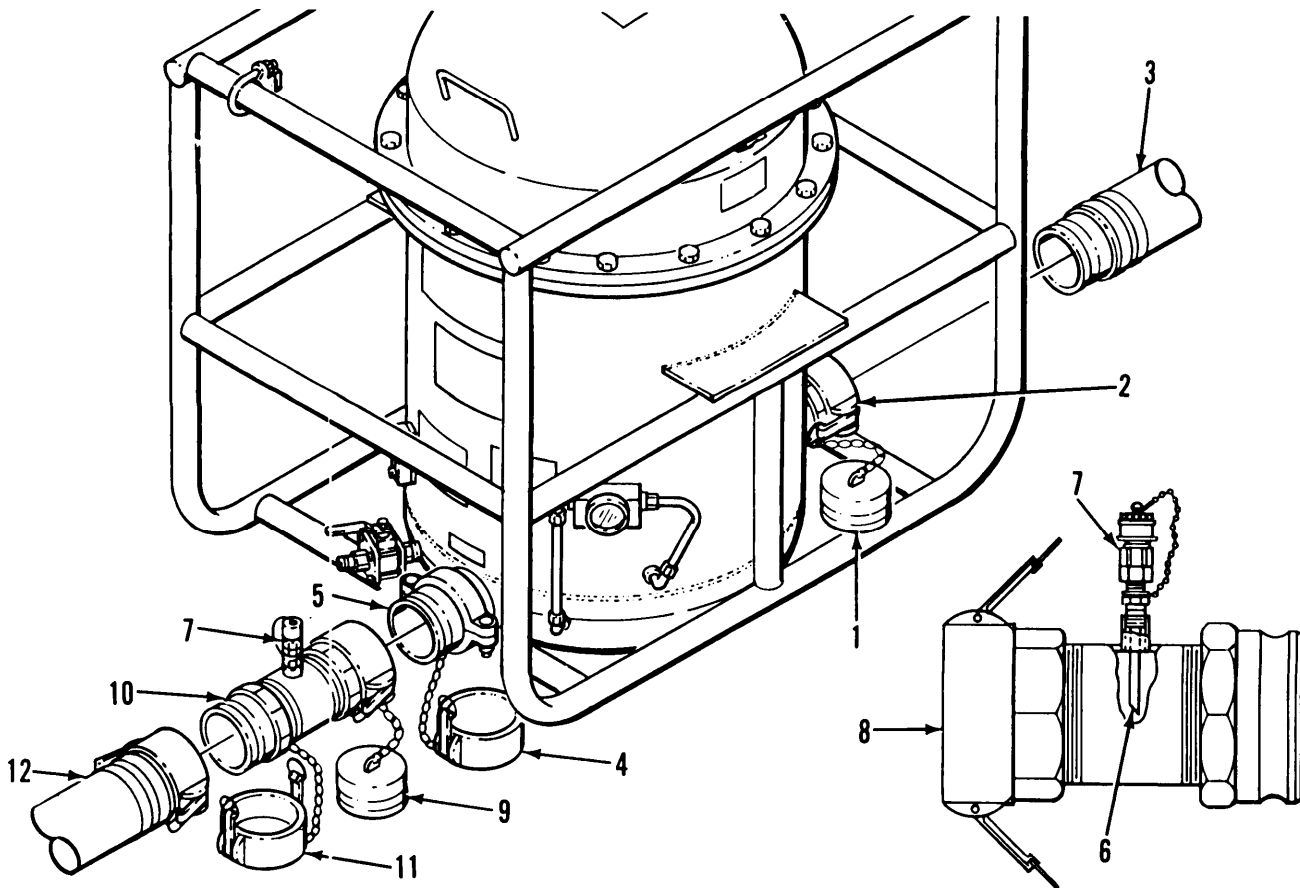

2-5 OPERATION

a. Starting.

- (1) Perform BEFORE operation PMCS.
- (2) Slowly open air vent valve by pushing in and turning until the handle is engaged in the slot.
- (3) Make sure that water drain valve is closed.
- (4) Start the system pumping unit.
- (5) Open external up-stream valve slightly to fill the filter/separator slowly with as little pressure as possible.
- (6) When vessel is completely filled fuel will begin to come from the vent valve. Close vent valve and make a visual inspection for leaks.
- (7) Fully open any down-stream valve and then fully open up-stream valve to begin fuel pumping operation.
- (8) Perform DURING operation PMCS.
- (9) If differential pressure indicates in the RED PORTION, STOP OPERATION IMMEDIATELY and notify unit maintenance. If gage indicates in yellow, refer to Table 3-1.
- (10) If ball in sight gage reaches the mark on gage body, open manual drain valve to drain water.

b. Fuel Sampling.

- (1) It is mandatory that the performance of filter/separators on all aircraft refueling equipment be checked every 30 days through the submission of samples taken from the effluent stream of the filter/separators.
- (2) The adapter attached to the filter/separator's outlet coupling contains a sampling probe, which extends into the fuel flow. A Detector Kit, NSN 6640-00-244-9478, can be attached to the sampling probe to obtain fuel samples.

NOTE

For disposal of contaminated fuel, refer to FM 10-20.

2-6 SHUTDOWN

a. Stopping.

- (1) Stop the system pumping unit.
- (2) Close the up-stream and down-stream valves to isolate the filter/separator from the system.

(3) Open the manual drain valve and drain any accumulated water.

(4) Open air vent valve. If shutdown is temporary, leave vent valve open until system is restarted.

b. Disconnection.

(1) Provide an adequate container and open manual drain valve to drain filter/separator.

(2) Disconnect hoses from inlet and outlet and drain any residual fuel.

(3) Disconnect the adapter from the filter/separator outlet and install dust cap and plug on adapter couplings.

(4) Install dust cap on filter/separator outlet coupling and plug on inlet coupling.

Section IV. Operation Under Unusual Conditions

2-7 OPERATING IN UNUSUAL CONDITIONS

a. Operation in Cold Temperatures. (Below 32°F (0°C))

(1) If a heated shelter cannot be provided, locate unit so that natural barriers can be utilized to the fullest extent possible to prevent water in the filter/separator from freezing.

(2) Prior to stopping unit, drain all water from vessel and valve until clear fuel is discharged from the drain valve. This will prevent water from freezing in vessel. Do this at each shutdown of operation.

b. Operation in Dusty or Sandy Areas. Precaution must be taken to prevent foreign matter from entering inlet or outlet lines and valves during coupling operations. Remove dust plugs and caps only when ready for connections to be made. Replace dust plugs and caps as soon as connections are broken.

c. Operation Under Rainy or Humid Conditions.

(1) Rainy or extreme humid conditions may cause unusual amounts of water to be entrained in the fuel. Water may need to be drained at more frequent intervals in these conditions.

(2) Erect a shelter to prevent the entrance of rain into the interior of the filter/separator when it is opened for servicing.

d. Operation in Salt Water Areas. To prevent corrosion, wipe or flush down the exterior of the filter/separator daily with fresh water. Check all painted surfaces for cracked, chipped, peeled or blistered paint. Keep filter elements and inside of unit protected from exposure to salt water.

e. Operation in High Ambient Temperatures. Leave vent valve closed to prevent loss of fuel by expansion during shutdown and open the valve to the inlet of the filter/separator. Vent the unit prior to restarting.

2-8 LOCATION OF DATA AND IDENTIFICATION PLATES

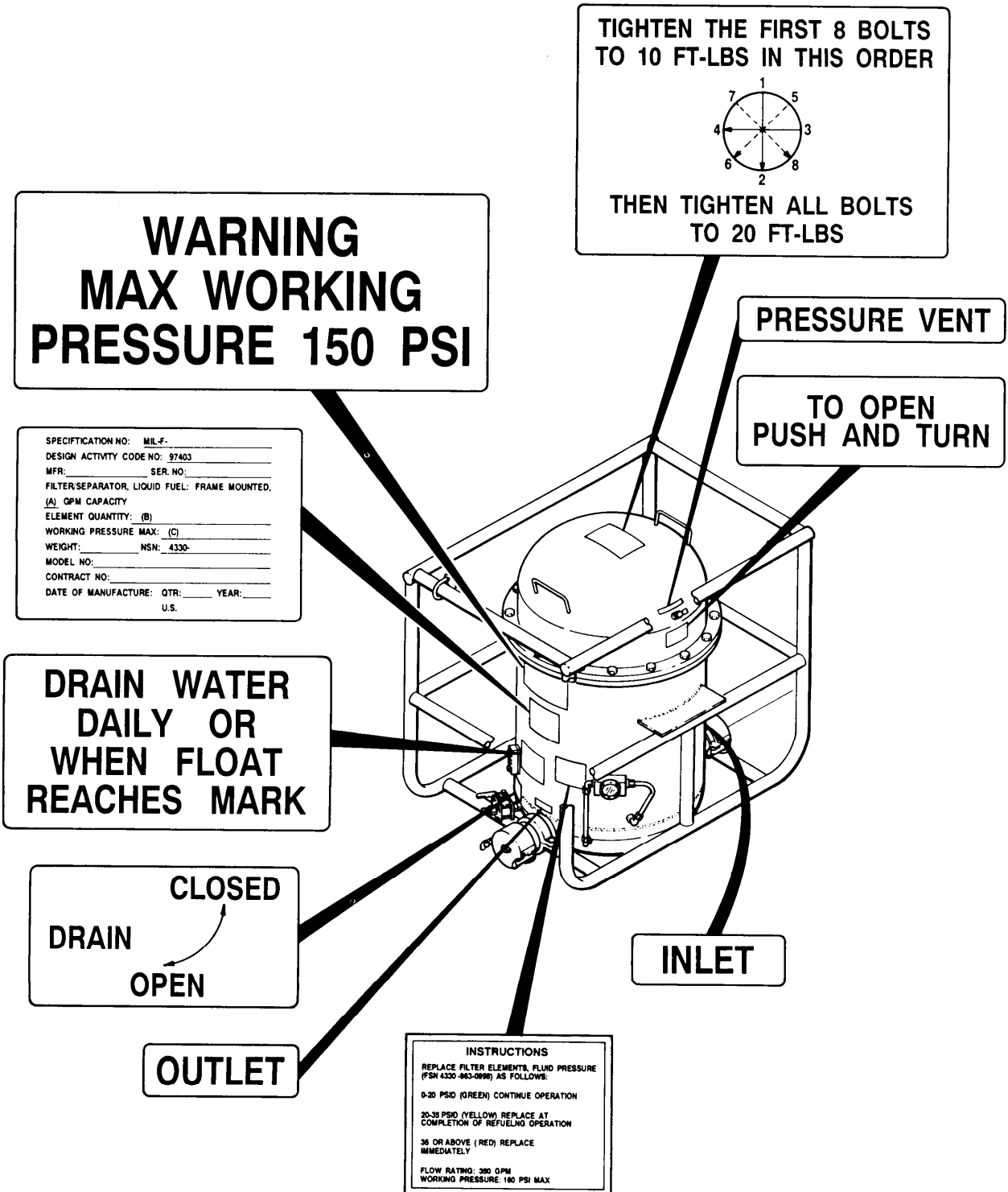

CHAPTER 3

OPERATOR MAINTENANCE INSTRUCTIONS

Section I. Lubrication Instructions 3-1

Section II. Troubleshooting Procedures.. . . . 3-1

 3-1 Introduction 3-1

Section III. Maintenance Instructions 3-2

Section I. Lubrication Instructions

No lubrication is required.

Section II. Troubleshooting Procedures

3-1 INTRODUCTION

- a. Table 3-1 lists common malfunctions that you may find with your equipment. Perform the tests, inspections, and corrective actions in the order they appear in the table.
- b. This table cannot list all the malfunctions that may occur, all the tests and inspections needed to find the fault, or all the corrective actions needed to correct the fault. If the equipment malfunction is not listed or actions listed do not correct the fault, notify your supervisor.

Table 3-1. Troubleshooting

MALFUNCTION
TEST OR INSPECTION
CORRECTIVE ACTION

1. Differential Pressure Gage indication is in yellow (20-35 psid).
 - Step 1. Check pump operating speed.
Reduce pump speed if operating above 350 GPM.
 - Step 2. Check for obstruction or kink in discharge line.
Remove obstruction or straighten line.
 - Step 3. Filter elements dirty.
Complete operation and notify Unit Maintenance.

Table 3-1. Troubleshooting (Cont'd)

MALFUNCTION	TEST OR INSPECTION	CORRECTIVE ACTION
2. Leaks at couplings.		<p>Step 1. Check to see that cam handles are fully closed. Drive cams home to secure coupling.</p> <p>Step 2. Stop operation and check female couplings for gaskets. Replace damaged or missing gaskets.</p>
3. Inadequate output.		<p>Step 1. Check pump flow rate and performance. Increase pump flow.</p> <p>Step 2. Check for obstruction or kink in discharge line. Remove obstruction or straighten line.</p> <p>Step 3. Check differential pressure gage reading. if indication is in red (above 35 psid) stop operation and notify unit maintenance.</p>

Section III. Maintenance Procedures

3-2 GENERAL

Operator maintenance on the filter/separator consists of only the tasks and procedures stated in the operator Preventive Maintenance Checks and Services (PMCS) chart. Refer to the operator's PMCS chart and perform all tasks outlined at the intervals specified.

CHAPTER 4

UNIT MAINTENANCE

Section I. Repair Parts and Special Tools List**4-1. COMMON TOOLS AND EQUIPMENT**

For authorized common tools and equipment, refer to the Modified Table of Organization and Equipment (MTOE), CTA 50-970, or CTA 8-100, as applicable to your unit.

4-2. SPECIAL TOOLS, TMDE AND SUPPORT EQUIPMENT

No special tools and equipment are required for maintenance of the filter/separator.

4-3. REPAIR PARTS

Repair parts are listed and illustrated in Appendix C of this manual.

Section II. Service Upon Receipt of Materiel**4-4. INSPECTION**

- a. Inspect the equipment for damage incurred during shipment. If the equipment has been damaged, report the damage on SF 364, Report of Discrepancies.
- b. Check the equipment against the packing slip to see if the shipment is complete. Report all discrepancies in accordance with the instructions of DA PAM 738-750.

Section III. Preventive Maintenance Checks and Services (PMCS)

- a. General. A PMCS table, Table 4-1, has been provided so you can keep your equipment in good operating condition and ready for its primary mission.
- b. Warnings and Cautions. Always observe the WARNINGS and CAUTIONS appearing in the PMCS table. Warnings and cautions appear before the procedure to which they apply. You must observe these WARNINGS and CAUTIONS to prevent serious injury to yourself and others or prevent damage to your equipment.
- c. Explanation of Columns.
 - (1) Item No. Numbers in this column are for reference. When completing DA Form 2404 (Equipment Inspection and Maintenance Worksheet), include the item number for the check/service indicating a fault. Item numbers also appear in the order that you must do checks and services for the intervals listed.
 - (2) Interval. This column tells you when you must do the procedure in the procedure column.
 - (3) Item to Check/Service. This column lists the name of the item to be checked or serviced.

- (4) Procedure. This column gives the procedure you must do to check or service the item listed in the Check/Service column to know if the equipment is ready or available for its intended mission or for operation. You must do the procedure at the time stated in the interval column.
- (5) Not Fully Mission Capable If:. Information in this column tells you what faults will keep your equipment from being capable of performing its primary mission. If you make check and service procedures that show faults listed in this column, do not operate the equipment. Follow standard operating procedure for maintaining the equipment or reporting equipment failure.

f. Other Table Entries. Be sure to observe all special information and notes that appear in your table.

Table 4-1. Preventive Maintenance Checks and Services

ITEM NO.	INTERVAL	ITEM TO BE CHECKED OR SERVICED	PROCEDURE	NOT FULLY MISSION CAPABLE IF:
1	QUARTERLY	Cover Bolts	Check for tightness and torque as required.	
2	QUARTERLY	Diff. Pressure Gage	Check for damage.	Gage is damaged.
3	QUARTERLY	Sight Gage	Check body for cracks and ball float for damage.	Gage is damaged.
4	QUARTERLY	Ground Rod	Check for missing or damaged sections.	Ground rod is missing or damaged.
5	QUARTERLY	Tank and Frame	Inspect for damage or signs of rust. Clean and repaint.	

Section IV. Troubleshooting

4-5. INTRODUCTION

- a. Table 4-2 lists common malfunctions that you may find with your equipment. Perform the tests, inspections, and corrective actions in the order they appear in the table.
- b. This table cannot list all the malfunctions that may occur, all the tests and inspections needed to find the fault, or all the corrective actions needed to correct the fault. If the equipment malfunction is not listed or actions listed do not correct the fault, notify your supervisor.

Table 4-2. Troubleshooting

MALFUNCTION	TEST OR INSPECTION	CORRECTIVE ACTION
1. Differential pressure gage indication is in red (above 35 psid).	Step 1. Check for dirty filter elements. Replace elements and clean canisters. (Para. 4-6)	Step 2. Test gage operation. (Para. 4-8) Replace defective gage. (Para. 4-8)

Section V. Maintenance Procedures

MAINTENANCE OF COVER, CANISTERS AND ELEMENTS

4-6. REPLACE ELEMENTS

This task covers: a. Removal b. Service c. Installation

INITIAL SETUP

Tools

General Mechanic Tool Kit (Appendix B, Section III, Item 4)
Torque Wrench (Appendix B, Section III, Item 7)

Materials/Parts

Cover preformed packing (Appendix H, Item 1)
Lock washer (16) (Appendix H, Item 2)
Filter element (18) (Appendix H, Item 3)
Silicone Compound (Appendix E, Section II, Item 2)
Dry Cleaning Solvent (Appendix E, Section II, Item 1)
Rags, Wiping (Appendix E, Section II, Item 5)
Gloves (Appendix E, Section II, Item 6, 7 or 8)

Equipment Conditions

System Shut down

General Safety Instructions

WARNING

Do not smoke within 50 feet (15.34 meters) of filter/separator.

Fuel is toxic to skin, eyes and respiratory tract.

Silicone Compound is toxic to skin, eyes and respiratory tract.

Dry cleaning solvent is potentially dangerous to personnel and property.

Compressed air can create airborne particles that may enter the eyes.

NOTE

Discard all mandatory replacement parts.

REMOVAL

- a. Provide a suitable container to receive fuel and open manual drain valve (1) to drain contents of filter/separator.
- b. Open air valve (2) to vent vessel.
- c. Remove nuts (3), lock washers (4), bolts (5) and flat washers (6).

WARNING

Fuel is toxic to skin, eyes and respiratory tract. Wear skin and eye protection when handling internal components of the filter/separator. Provide adequate ventilation.

- d. Lift cover (7) from filter/separator and remove preformed packing (8).
- e. Loosen and remove band clamp (9) from around canisters (10).
- f. Remove each canister (10) by pushing down and turning counterclockwise, then lifting straight up and out.
- g. Remove and discard all filter elements (11).

SERVICE**WARNING**

Dry cleaning solvent, P-D-680, used to clean parts is potentially dangerous to personnel and property. Avoid repeated and prolonged skin contact. Do not use near open flame or excessive heat. Flash point of solvent is 100 - 138 degrees F (38 - 59 degrees C).

When using compressed air, wear safety goggles or glasses and ensure air blast is not directed at another person. Do not direct compressed air against the skin.

- a. Inspect canisters for dirty condition. If necessary, clean the teflon screen in canister using dry cleaning solvent and low pressure compressed air.
- b. Examine the wave spring inside canisters for damage. Refer to paragraph 4-7 for replacement procedure if damage is evident.

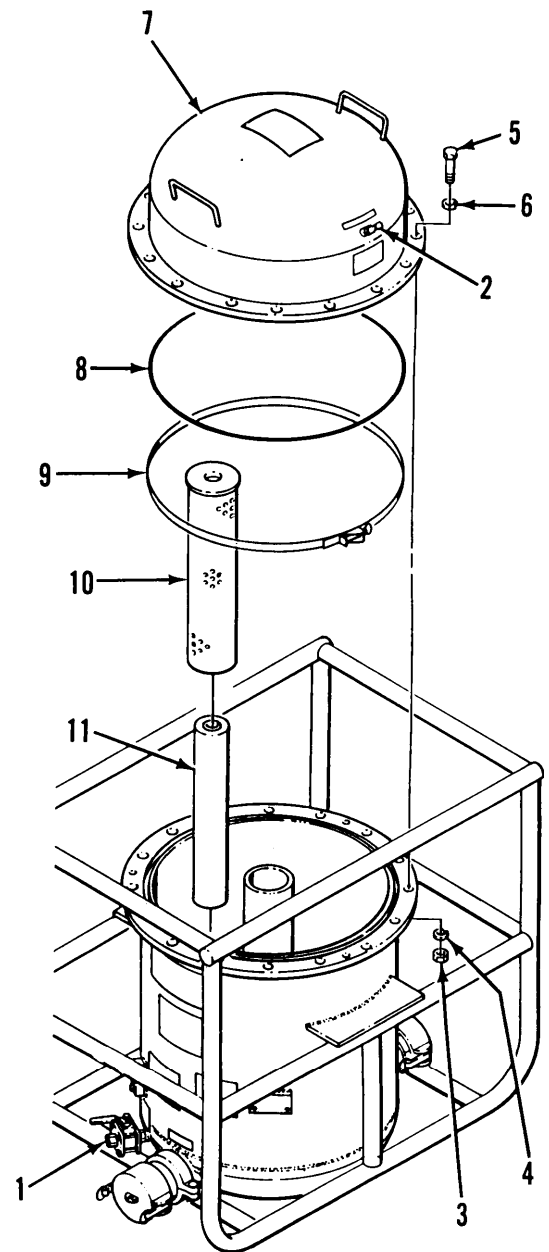

INSTALLATION

WARNING

Silicone compound, MIL-S-8660, is toxic to skin, eyes and respiratory tract. Skin and eye protection required. Good general ventilation is normally adequate.

CAUTION

Oils from the skin can penetrate the surface of the elements and cause them to be ineffective. When installing elements, do not touch the element surface.

- a. Open one end of bag containing a new element (11). Apply a coating of silicone compound to the preformed packing in the end of the element.
- b. Insert the element (11) into the filter/separator vessel and install it on the outlet port at the bottom of the vessel.
- c. Repeat steps a and b for the remaining elements, then remove the bags from the elements.
- d. Install a canister (10) over each element (11), engaging the canister over the outlet port dogs (13). Press down and turn the canister clockwise to lock it in place.
- e. Position the band clamp (9) around the canisters (10) and tighten clamp.
- f. Apply a light coating of silicone compound to preformed packing (8) and install in groove in top of vessel.
- g. Position cover (7) on vessel and install bolts (6), flat washers (5), lock washers (4) and nuts (3). Tighten nuts hand tight.
- h. Refer to the instruction plate (12) on top of the cover (7) and tighten the first eight bolts (6) in the order shown to 10 ft-lbs then tighten all bolts to 20 ft-lbs.
- i. Close air valve (2) and drain valve (1).

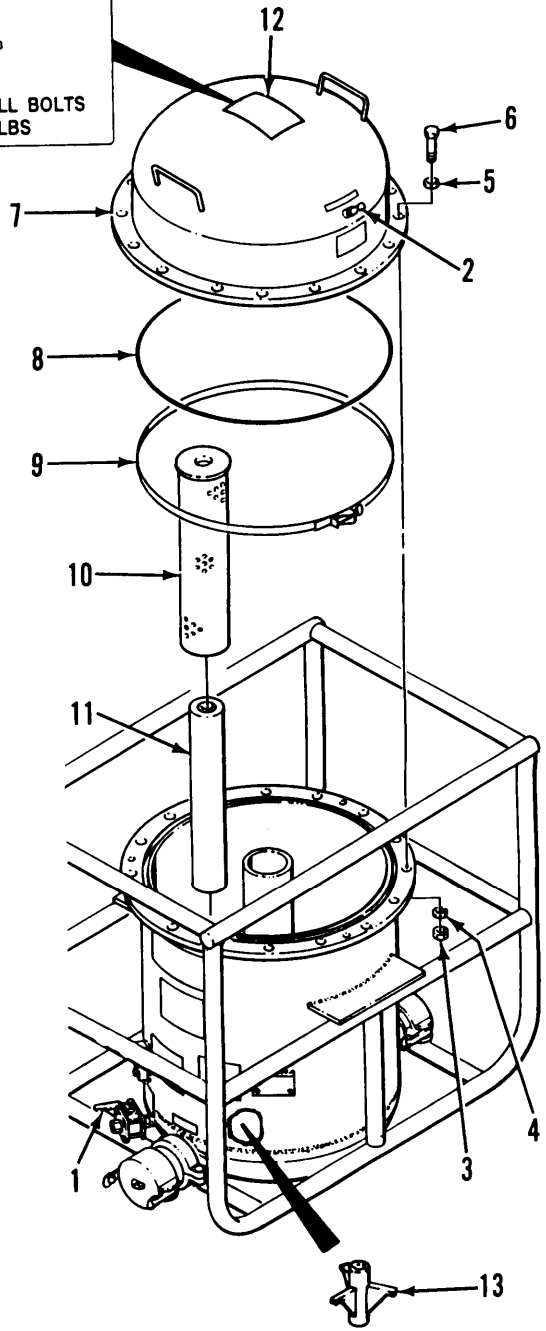
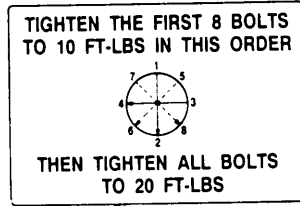

4-7. REPAIR CANISTER

This task covers: a. Repair

INITIAL SETUP

Tools

General Mechanic Tool Kit (Appendix B, Section III, Item 4)

Materials/Parts

Spring Tension Washer (Appendix H, Item 4)

Equipment Conditions

Canisters Removed (Para. 4-6)

General Safety Instructions

WARNING

Do not smoke within 50 feet (15.34 meters) of filter/separator.

REPAIR

CAUTION

Do not allow any metal object to come in contact with teflon coated screen in canister.

- a. Insert a flat blade screwdriver in notch (1) nearest boss (2) and engage it behind spring washer (3).
- b. Press end of spring washer (3) to center of canister mouth. Grasp spring washer with pliers and pull inward and out.
- c. Install new spring washer (3) so that one end is against boss (2) in groove and compress spring washer into place.
- d. Refer to paragraph 4-6 and install canister.

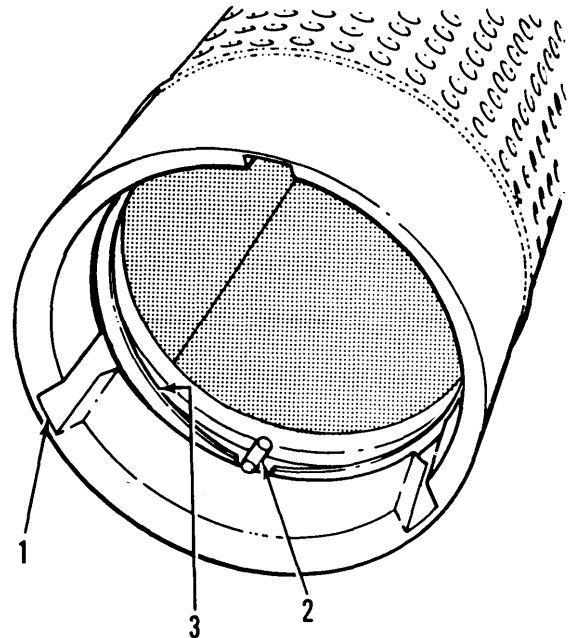

MAINTENANCE OF GAGES, VALVES AND LINES

4-8. REPLACE DIFFERENTIAL PRESSURE GAGE

This task covers: a. Removal b. Testing c. Installation

INITIAL SETUP

Tools

General Mechanic Tool Kit (Appendix B, Section III, Item 4)

Materials/Parts

Sealing Compound (Appendix E, Section II, Item 3)

Equipment Conditions

System Shut Down

General Safety Instructions

WARNING

Do not smoke within 50 feet (15.34 meters) of filter/separator.

REMOVAL

- a. Provide a suitable container to receive fuel and open manual drain valve (1) to drain contents of filter/separator.
- b. Open air valve (2) to vent vessel.
- c. Disconnect tube nuts (3) at elbows (11).
- d. Remove screws (5), lock washers (6) and flat washers (7) to remove gage (8) from filter/separator.
- e. Remove tube assemblies (4).
- f. Remove elbow (9) and straight adapter (10) from gage (8).

TESTING

- a. Apply a regulated air or hydrostatic pressure at the "IN" port.
- b. Increase the pressure to the "IN" port slowly. The gage should indicate the applied pressures within ± 2 psi.
- c. If indication is not in range, replace gage.

INSTALLATION

- a. Apply sealing compound to threads of elbow (9) and straight adapter (10). Install in gage (8).
- b. Connect tube assemblies (4) to elbow (9) and adapter (10).
- c. Position gage (8) on filter/separator and install flat washers (7), lock washers (6) and screws (5).
- d. Apply sealing compound to threads of elbows (11) and install tube assemblies (4) between elbows (11) and gage fittings (9 and 10).
- e. Close air valve (2) and drain valve (1).

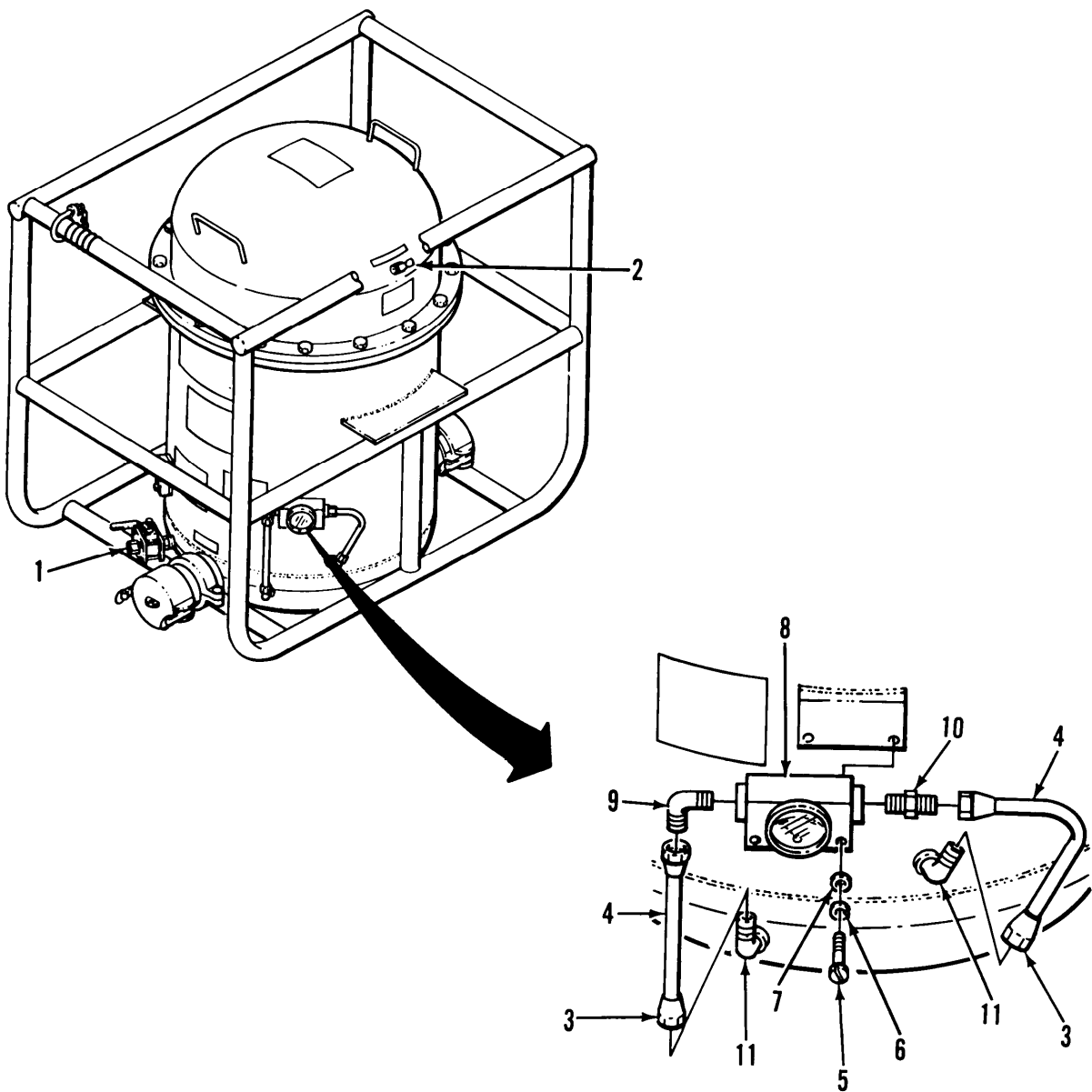

4-9. REPLACE SIGHT GAGE

This task covers: a. Removal b. Installation

INITIAL SETUP

Tools

General Mechanic Tool Kit (Appendix B, Section III, Item 4)

Materials/Parts

Gasket (Appendix H, Item 5)

Equipment Conditions

System Shut Down

General Safety Instructions

WARNING

Do not smoke within 50 feet (15.34 meters) of filter/separator.

REMOVAL

- a. Provide a suitable container to receive fuel and open manual drain valve (1) to drain contents of filter/separator below level of sight gage.
- b. Open air valve (2) to vent vessel.
- c. Remove screws (3) and flat washers (4). Pull gage body (5) from mount on filter/separator and remove float ball (6).
- d. Remove gasket (7).

INSTALLATION

- a. Place float ball (6) in gage body (5) and position gage body and gasket (7) on filter/separator.
- b. Secure body in place with screws (3) and flat washers (4). Tighten screws snugly.
- c. Close vent valve (2) and drain valve (1).

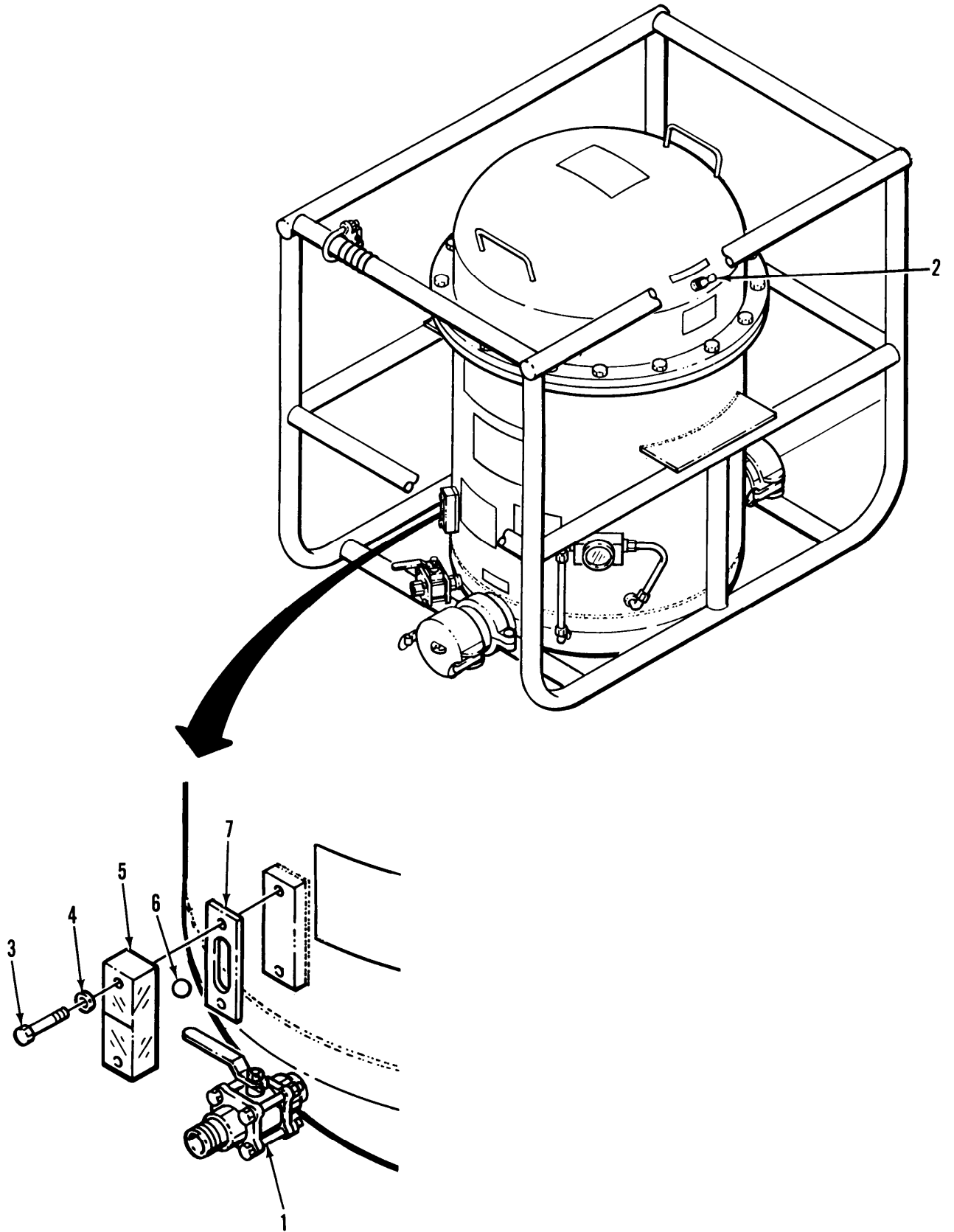

4-10. REPAIR PRESSURE VENT VALVE

This task covers: a. Removal b. Repair c. Installation

INITIAL SETUP

Tools

General Mechanic Tool Kit (Appendix B, Section III, Item 4)

Materials/Parts

Sealing Compound (Appendix E, Section II, Item 3)

Equipment Condition

System Shut Down

General Safety Instructions

WARNING

Do not smoke within 50 feet (15.34 meters) of filter/separator.

REMOVAL

- a. Open valve (1) by pushing in and turning handle to engage in slot.
- b. Unscrew valve (1) from cover (2).

REPAIR

Remove preformed packing (3) and install new preformed packing.

INSTALLATION

- a. Apply sealing compound to threads of valve (1).
- b. Screw valve (1) into cover (2).

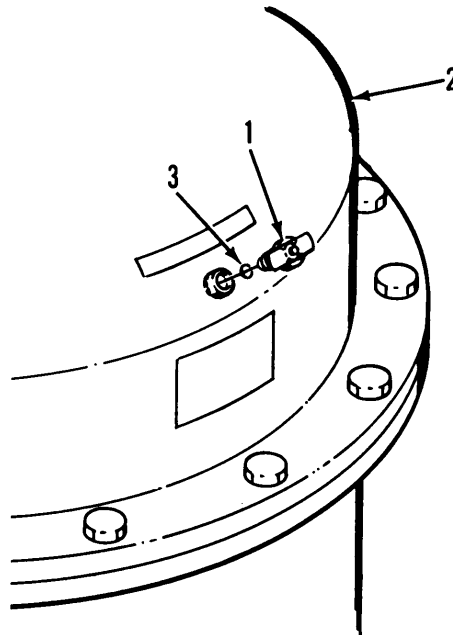

4-11. REPLACE WATER DRAIN VALVE

This task covers: a. Removal b. Installation

INITIAL SETUP

Tools

General Mechanic Tool Kit (Appendix B, Section III, Item 4)
Wrench, Pipe (Appendix B, Section III, Item 6)

Materials/Parts

Sealing Compound (Appendix E, Section II, Item 3)

Equipment Conditions

System Shut Down

General Safety Instructions

WARNING

Do not smoke within 50 feet (15.34 meters) of filter/separator.

REMOVAL

- a. Provide a suitable container to receive fuel and open manual drain valve (1) to drain contents of filter/separator.
- b. Open air valve (2) to vent vessel.
- c. Unscrew drain valve (1) from vessel nipple (3).
- d. Unscrew pipe nipple (4) from drain valve (1) outlet.

INSTALLATION

- a. Screw pipe nipple (4) into outlet of drain valve (1).
- b. Apply sealing compound to threads of vessel nipple (3) and screw drain valve (1) onto nipple (3).
- c. Position drain valve handle to closed position. Close air valve (2).

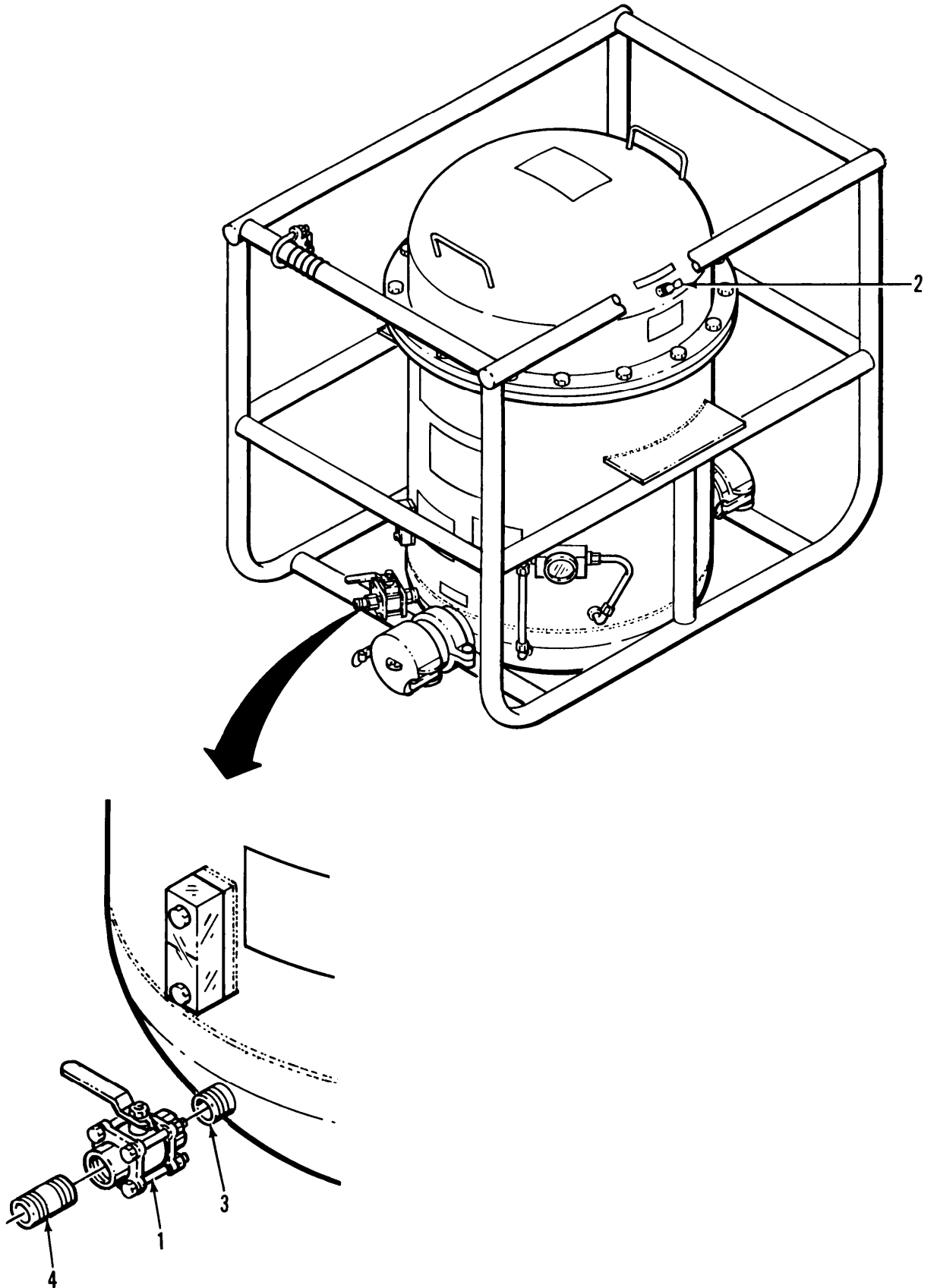

MAINTENANCE OF TANK AND FRAME

4-12. REPLACE INLET/OUTLET COUPLINGS

This task covers: a. Removal b. Installation

INITIAL SETUP

Tools

General Mechanic Tool Kit (Appendix B, Section III, Item 4)

Equipment Conditions

Disconnected from fueling system.

NOTE

The procedure for inlet and outlet couplings is identical

REMOVAL

- a. Remove nuts (1) and bolts (2) to separate halves of coupler (3).
- b. Remove coupling (4) and gasket (5).

INSTALLATION

- a. Place gasket (5) on flange of coupling (4) and position coupling on vessel flange (6).
- b. Slide the gasket (5) so that it is positioned on both flanges.
- c. Install halves of coupler (3) and fasten with bolts (2) and nuts (1).

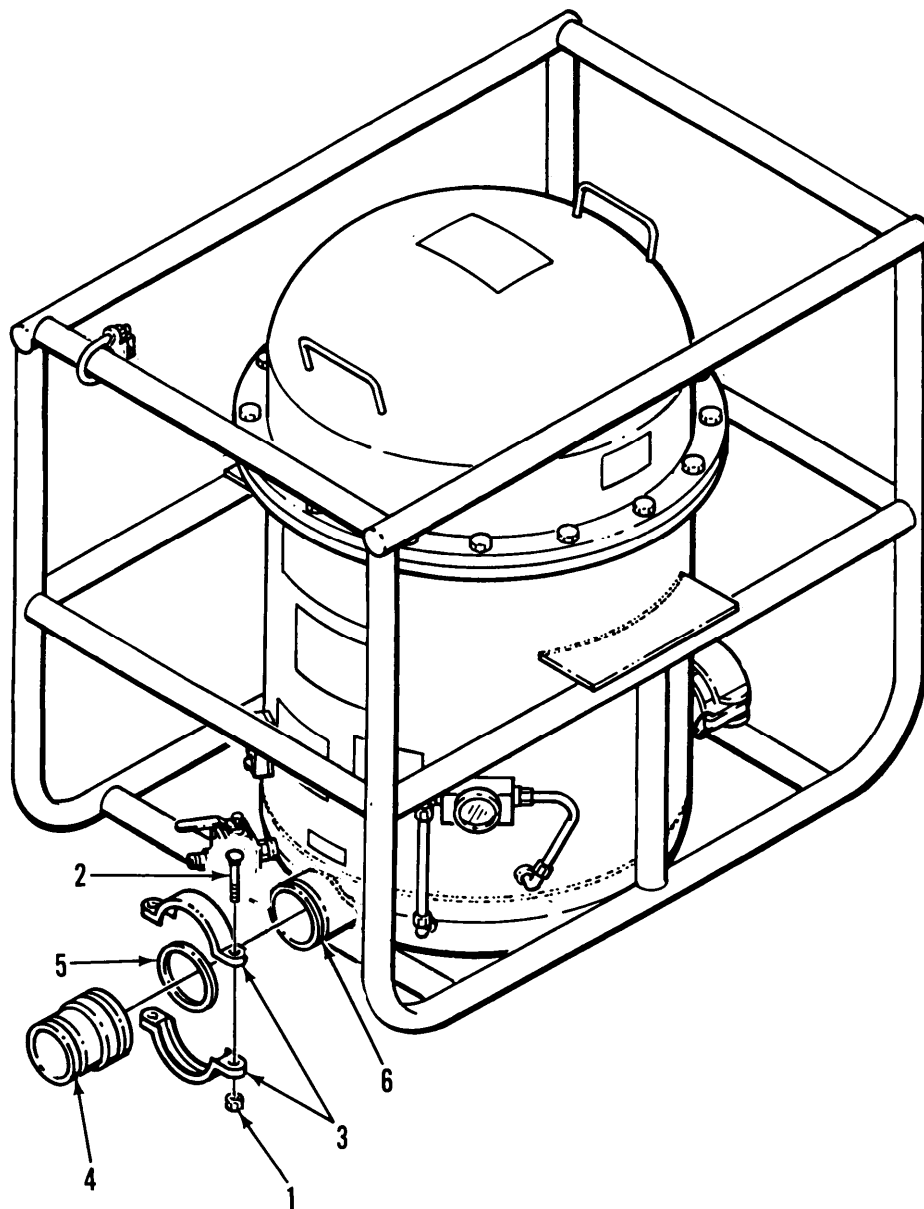

4-13. REPLACE GROUND CLAMP

This task covers: a. Removal b. Installation

INITIAL SETUP

Tools

General Mechanic Tool Kit (Appendix B, Section III, Item 4)

Equipment Conditions

System Shut Down

REMOVAL

- a. Loosen screws (1) to release ground cable (2).
- b. Remove nuts (3) and lockwashers (4).
- c. Remove u-bolt (5) and clamp (6) from frame (7).

INSTALLATION

- a. Assemble u-bolt (5) and clamp (6) to frame (7).
- b. Install lockwashers (4) and nuts (3).
- c. Insert ground cable (2) in clamp (6) and tighten screws (1).

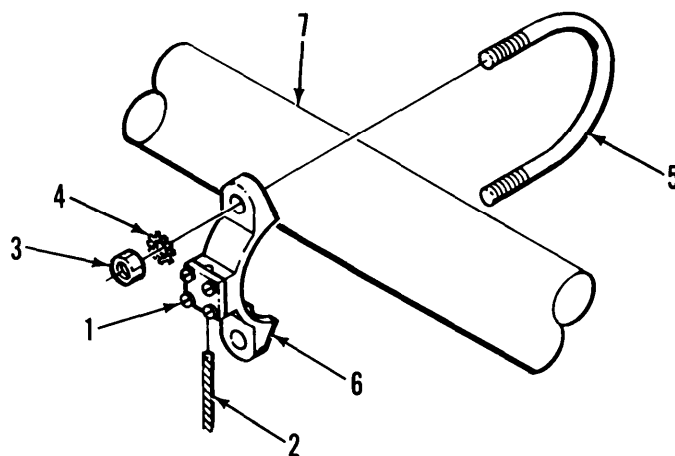

4-14. REPLACE DATA PLATE

This task covers: a. Replacement

INITIAL SETUP

Materials/Parts

Adhesive, Rubber Base (Appendix E, Section II, Item 4)

REPLACE

- a. Refer to paragraph 2-8 for location of data and identification plates.
- b. Install missing data plates using adhesive.

MAINTENANCE OF WATER DETECTOR ADAPTER
--

4-15. REPAIR ADAPTER ASSEMBLY

This task covers: a. Disassembly b. Repair

INITIAL SETUP

Tools

General Mechanic Tool Kit (Appendix B, Section III, Item 4)
Vise
Wrench, Strap (Appendix B, Section III, Item 2)

Materials/Parts

Sealing Compound (Appendix E, Section II, Item 3)

Equipment Conditions

Adapter Assembly removed from Filter/Separator

DISASSEMBLY

- a. Clamp the adapter assembly securely in a vise and remove sampling probe (1).
- b. Pull cam handles on dust cap (2) out and remove dust cap.
- c. Pull cam handles of coupling half (3) out and remove dust plug (4).
- d. Unscrew coupling halves (3 and 5) from the adapter nipple (6).

REPAIR

Inspect components for damage and replace damaged parts. Check gasket (7) in coupling half (3) and replace if damaged or worn.

ASSEMBLY

- a. Be sure that there is a gasket (7) in coupling half (3).
- b. Clamp adapter nipple (6) in a vise. Apply sealing compound to threads of nipple and install coupling halves (3 and 5).
- c. Install dust plug in coupling half (3) and drive cams home to secure plug.
- d. Install dust cap (2) on coupling half (5) and drive cams home to secure cap.
- e. Apply sealing compound to threads of sampling probe (1) and screw probe into adapter nipple (6) making sure that the bevel of the probe is facing the end with female coupling half (3).

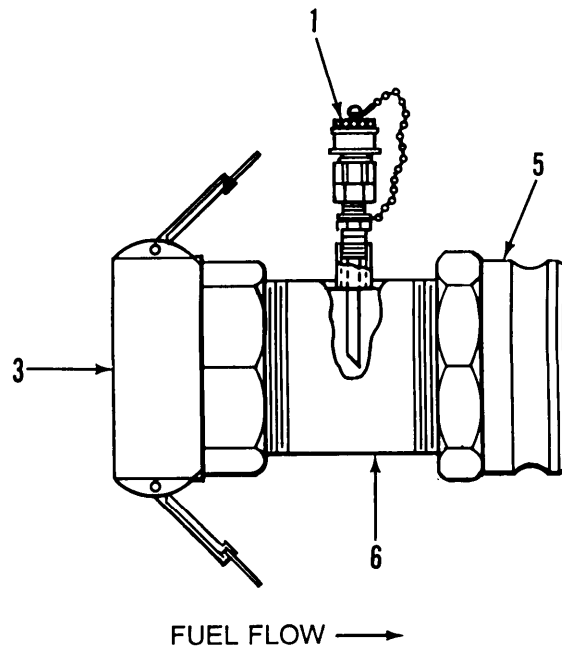
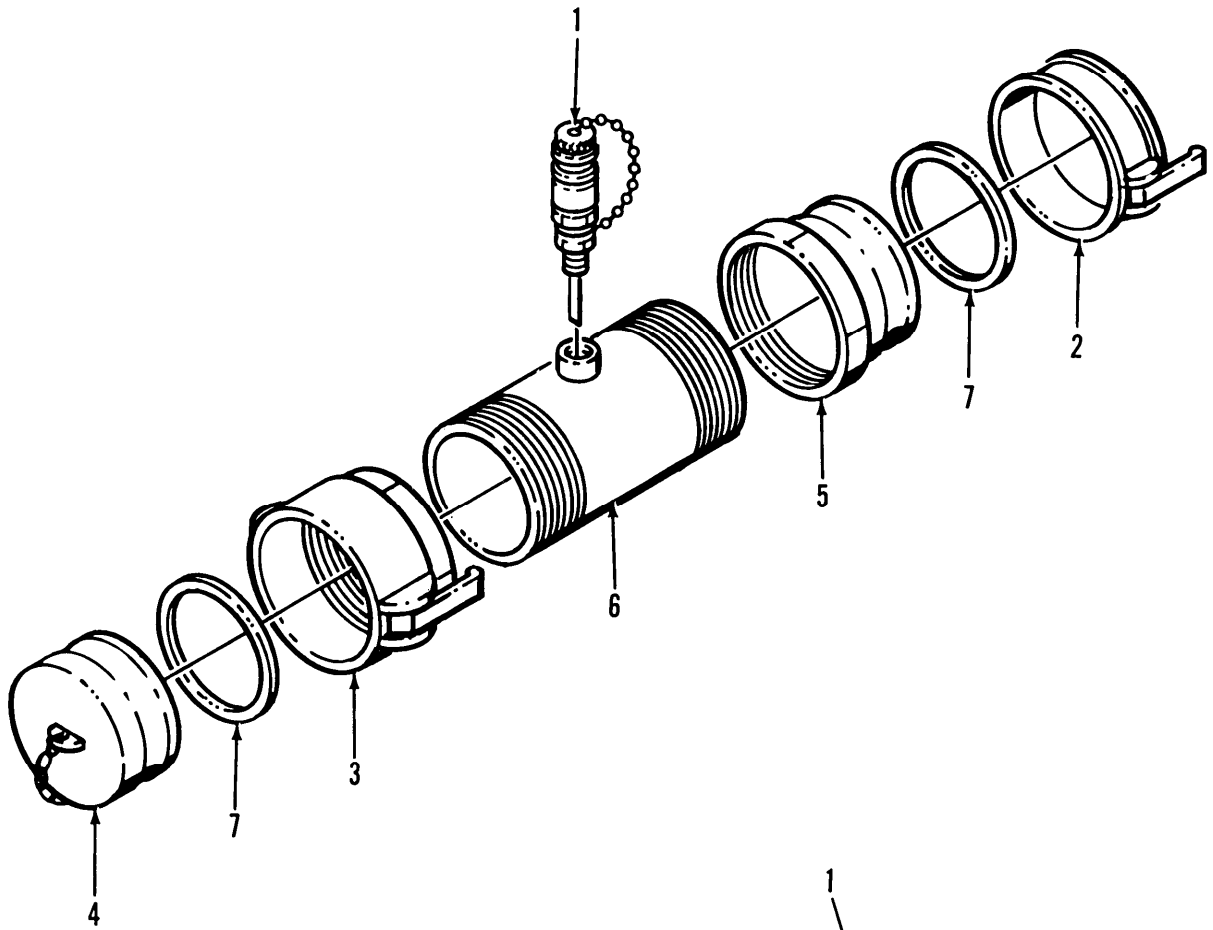

Section VI. Preparation for Shipment or Storage

4-16. SHORT TERM STORAGE Store the filter/separator as follows:

- a. Isolate the filter/separator from the pipeline by closing the inlet blocking valve.
- b. Open the manual drain valve and drain the fuel in the tank into a suitable container.
- c. Disconnect inlet and outlet hoses from filter/separator.
- d. Disconnect ground rod.

WARNING

Two personnel are required to lift the filter/separator to avoid injury.

- e. Remove unit from pipeline.

4-17. INTERMEDIATE TERM STORAGE Refer to the following documents for information relative to storing the filter/separator.

- a. TM 38-230-1 Preservation and packing of military equipment.
- b. AR-750-1 Army Materiel Maintenance Policy and Retail Maintenance Operations.
- c. MIL-F-52429 Packing of fuel separators.

4-18. ADMINISTRATIVE STORAGE

- a. Placement of equipment in administrative storage should be for short periods of time when a shortage of maintenance effort exists. Items should be in mission readiness within 24 hours or within the time factors as determined by the directing authority. During the storage period appropriate maintenance records will be kept.
- b. Before placing equipment in administrative storage, current Preventive Maintenance Checks and Services (PMCS) should be completed, shortcomings and deficiencies should be corrected, and all modification work orders (MWO's) should be applied.
- c. Storage site selection. Inside storage is preferred for items selected for administrative storage. If inside storage is not available, trucks, vans, conex containers and other containers may be used.

4-19. PREPARATION FOR SHIPMENT Refer to the following documents.

- a. TM 38-230-1 Preservation and Packing of Military Equipment.
- b. MIL-F-52429 Packing of Fuel Separators.

CHAPTER 5
DIRECT SUPPORT MAINTENANCE

Section I. Repair Parts and Special Tools List

5-1. COMMON TOOLS AND EQUIPMENT

For authorized common tools and equipment, refer to the Modified Table of Organization and Equipment (MTOE), CTA 50-970, or CTA 8-100, as applicable to your unit.

5-2. SPECIAL TOOLS, TMDE AND SUPPORT EQUIPMENT

No special tools and equipment are required for maintenance of the filter/separator.

5-4. REPAIR PARTS

Repair parts are listed and illustrated in Appendix C of this manual.

Section II. Troubleshooting

5-4. GENERAL

Refer to Tables 3-1 and 4-2 for troubleshooting procedures.

Section III. Maintenance Procedures

MAINTENANCE OF TANK AND FRAME

5-5. REPAIR TANK AND FRAME

This task covers: a. Repair

Tools

General Mechanic Tool Kit (Appendix B, Section III, Item 4)
Shop Equipment, Welding (Appendix B, Section III, Item 5)

Materials/Parts

Dry Cleaning Solvent (Appendix E, Section II, Item 1)
Rags, Wiping (Appendix E, Section II, Item 5)

Equipment Conditions

Filter elements removed (Para. 4-6)

General Safety Instructions

WARNING

Do not smoke within 50 feet (15.34 meters) of filter/separator.

Dry cleaning solvent is potentially dangerous to personnel and property.

WARNING

Dry cleaning solvent, P-D-680, used to clean parts is potentially dangerous to personnel and property. Avoid repeated and prolonged skin contact. Do not use near open flame or excessive heat. Flash point of solvent is 100 - 138 degrees F (38 - 59 degrees C).

When using compressed air, wear safety goggles or glasses and ensure air blast is not directed at another person. Do not direct compressed air against the skin.

REPAIR

- a. Clean the exterior of filter/separator by wiping down with dry cleaning solvent.
- b. Examine exterior and interior of tank for damage. If tank is damaged it must be replaced.
- c. Check frame welds for cracks or breaks. Welds will be repaired in accordance with TM9-237.
- d. Straighten bends found in frame.
- e. Check painted surfaces for chipped, blistered or missing paint. Treat and paint exposed surfaces in accordance with TM 43-0139 and MIL-T-704. Top coat shall be camouflage green 383 conforming to MIL-C-46168.
- f. Install elements (para. 4-6).

APPENDIX A**REFERENCES**

A-1. SCOPE This appendix contains all forms, pamphlets and technical manuals referenced in this manual.

A-2. FORMS

Recommended Changes to Publications	DA Form 2028
Recommended Changes to Publications	DA Form 2028-2
Equipment inspection and Maintenance Worksheet	DA Form 2404
Quality Deficiency Report (QDR)	SF 368
Report of Discrepancy (ROD))	SF 364

A-3. PAMPHLETS

The Army Maintenance Management System-Aviation (TAMMS-A)	DA Pam 738-750
Consolidated Index of Army Publication and Blank Forms	DA Pam 25-30

A-4. TECHNICAL MANUALS

Painting Instructions for Field Use	TM 43-0139
Procedures for Destruction of Equipment to Prevent Enemy Use	TM 750-244-3
Preservation and Packing of Military Equipment	TM 38-230-1
Welding Theory and Application	TM 9-237

A-5. TECHNICAL BULLETINS

Hand Portable Fire Extinguishers Approved for Army Use	TB 5-4200-200-10
--	------------------

A-6. FIELD MAINTENANCE

First Aid for Soldiers	FM 21-11
Organizational Maintenance of Military Petroleum Pipelines, Tanks, and Related Equipment	FM 10-20

A-7. ARMY REGULATIONS

Reporting of Item and Packaging Discrepancies	AR 735-11-2
Army Materiel Maintenance Policy and Retail Maintenance Operations	AR 750-1
Army Logistics Readiness and Sustainability	AR 700-138

APPENDIX B

MAINTENANCE ALLOCATION CHART

Section I. INTRODUCTION

B-1. GENERAL

a. This section provides a general explanation of all maintenance and repair functions authorized at various maintenance categories.

b. The Maintenance Allocation Chart (MAC) in Section II designates overall authority and responsibility for the performance of maintenance functions on the identified end item or component. The implementation of the maintenance functions upon the end item or component will be consistent with the assigned maintenance functions.

c. Section III lists the special tools and test equipment required for each maintenance function as referenced from Section II.

d. Section IV contains supplemental instructions and explanatory notes for a particular maintenance function.

B-2. MAINTENANCE FUNCTIONS

Maintenance functions will be limited to and defined as follows:

a. Inspect. To determine the serviceability of an item by comparing its physical, mechanical, and/or electrical characteristics with established standards through examination.

b. Test. To verify serviceability by measuring the mechanical or electrical characteristics of an item and comparing those characteristics with prescribed standards.

c. Service. Operations required periodically to keep an item in proper operating condition, i.e., to clean (includes decontaminate, when required), to preserve, to drain, to paint, or to replenish fuel, lubricants, chemical fluids, or gases.

d. Adjust. To maintain, within prescribed limits, by bringing into proper or exact position, or by setting the operating characteristics to specified parameters.

e. Aline. To adjust specified variable elements of an item to bring about optimum or desired performance.

f. Calibrate. To determine and cause corrections to be made or to be adjusted on instruments or test, measuring, and diagnostic equipment used in precision measurement. Consists of comparisons of two instruments, one of which is a certified standard of known accuracy, to detect and adjust any discrepancy in the accuracy of the instrument being compared.

g. Remove/Install. To remove and install the same item when required to perform service or other maintenance functions. Install is the act of emplacing, seating, or fixing into position an item, part, or module (component or assembly) in a manner to allow the proper functioning of an equipment or system.

h. Replace. To remove an unserviceable item and install a serviceable counterpart in its place. "Replace" is authorized by the MAC and is shown as the 3d position code of the SMR code.

B-2. MAINTENANCE FUNCTIONS - Continued

i. Repair. The application of maintenance services¹ or other maintenance actions² to restore serviceability to an item by correcting specific damage, fault, malfunction, or failure in a part, subassembly, module (component or assembly), end item, or system.

j. Overhaul. That maintenance effort (service/action) necessary to restore an item to a completely serviceable/operational condition as prescribed by maintenance standards in appropriate technical Publications i.e., DMWR). Overhaul is normally the highest degree of maintenance performed by the Army. Overhaul does not normally return an item to like new condition.

k. Rebuild. Consists of those services/actions necessary for the restoration of unserviceable equipment to a like new condition in accordance with original manufacturing standards. Rebuild is the highest degree of material maintenance applied to Army equipment. The rebuild operation includes the act of returning to zero those age measurements (hour/miles, etc.) considered in classifying Army equipment components.

B-3. EXPLANATION OF COLUMNS IN THE MAC, SECTION II

a. Column 1, Group Number. Column 1 lists functional group code numbers, the purpose of which is to identify components, assemblies, subassemblies, and modules with the next higher assembly.

b. Column 2, Component/Assembly. Column 2 contains the names of components, assemblies, subassemblies, and modules for which maintenance is authorized.

c. Column 3, Maintenance Function. Column 3 lists the functions to be performed on the item listed in Column 2. (For detailed explanation of these functions, see paragraph B-2).

d. Column 4, Maintenance Category. Column 4 specifies, by the listing of a work time figure in the appropriate subcolumn(s), the category of maintenance authorized to perform the function listed in Column 3. This figure represents the active time required to perform that maintenance function at the indicated category of maintenance. If the number or complexity of the tasks within the listed maintenance function vary at different maintenance categories, appropriate work time figures will be shown for each category. The work time figure represents the average time required to restore an item (assembly, subassembly, component, module, end item, or system) to a serviceable condition under typical field operating conditions. This time includes preparation time (including any necessary disassembly/assembly time), troubleshooting time, and quality assurance/quality control time in addition to the time required to perform the specific tasks identified for the maintenance functions authorized in the maintenance allocation chart. The symbol designations for the various maintenance categories are as follows:

- C Operator or crew.
- O Organizational maintenance.
- F Direct support maintenance.
- H General support maintenance.
- D Depot maintenance.

e. Column 5, Tools and Equipment. Column 5 specifies, by code, those common tool sets (not individual tools) and special tools, TMDE, and support equipment required to perform the designated function.

f. Column 6, Remarks. This column shall, when applicable, contain a letter code, in alphabetical order, which shall be keyed to the remarks contained in Section IV.

¹Services - inspect, test, service, adjust, aline, calibrate, or replace.

²Actions - welding, grinding, riveting, straightening, facing, remachining, or resurfacing.

B-4. EXPLANATION OF COLUMNS IN TOOL AND TEST EQUIPMENT REQUIREMENTS, SECTION III

- a. Column 1, Reference Code. The tool and test equipment reference code correlates with a code used in the MAC, Section II, Column 5.
- b. Column 2, Maintenance Category. The lowest category of maintenance authorized to use the tool or test equipment.
- c. Column 3, Nomenclature. Name or identification of the tool or test equipment.
- d. Column 4, National Stock Number. The National Stock Number of the tool or test equipment.
- e. Column 5, Tool Number. The manufacturer's part number.

B-5. EXPLANATION OF REFERENCE CODES, SECTION IV

- a. Column 1, Reference Code. The code recorded in column 6, Section II.
- b. Column 2, Remarks. This column lists information pertinent to the maintenance function being performed as indicated in the MAC, Section II.

Section II. MAINTENANCE ALLOCATION CHART

(1)	(2)	(3)	(4)					(5)	(6)
GROUP NUMBER	COMPONENT/ASSEMBLY	MAINT. FUNCTION	MAINTENANCE LEVEL					TOOLS & EQUIP.	REMARKS
			C	O	F	H	D		
01	Filter Separator	Inspect Service Test Repair Replace	0.6	0.7 0.8 0.8 1.3 6.0	3.0				
0101	Cover, Canisters & Elements Cover Preformed Packing	Inspect Replace		0.1 0.4				3, 4	
	Canister	Inspect Service Repair Replace		0.5 0.8 1.0 1.0				3, 4 1, 2 3, 4	A B
	Elements	Inspect Replace		0.1 1.0				3, 4	
0102	Gages, Valves & Lines Diff. Pressure Gage	Inspect Test Replace	0.1	0.8 1.0				3, 4	c
	Sight Gage	Inspect Replace	0.1	0.5				3, 4	
	Pressure Vent Valve	Inspect Repair Replace	0.1	0.3 0.5				3, 4 3, 4	D
	Water Drain Valve	Inspect Replace	0.1	0.3				3, 4	
0103	Tank & Frame Ground Rod Assembly	Inspect Replace	0.1	0.3				3, 4	
	Tank and Frame	Inspect Repair Replace	0.2	1.0	3.0			5	E
02	Water Detector Adapter	Inspect Repair Replace	0.2	0.8 0.7					
0201	Adapter Assembly	Inspect Repair Replace	0.1	0.8 0.5				2, 3, 4, 6 3, 4	F F

(1)	(2)	(3)	(4)					(5)	(6)
GROUP NUMBER	COMPONENT/ASSEMBLY	MAIN. FUNCTION	MAINTENANCE LEVEL					TOOLS & EQUIP	REMARKS
			C	O	F	H	D		
0202	Sampling Probe	Inspect Replace	0.1	0.2				3, 4	

MAINTENANCE ALLOCATION CHART
SECTION III. TOOL AND TEST EQUIPMENT REQUIREMENTS

(1) TOOL/TEST EQUIP. REF. CODE	(2) MAINTENANCE CATEGORY	(3) NOMENCLATURE	(4) NATIONAL/NATO STOCK NUMBER	(5) TOOL NUMBER
1	F	SHOP EQUIPMENT,AUTOMOTIVE MAINTENANCE AND REPAIR: FIELD MAINTENANCE,BASIC LESS POWER (19204)	4910-00-754-0705	SC 4910-95CL- A 31
2	O	WRENCH,STRAP 4-1/2-5 INCH	5120-00-262-8491	
3	O	SHOP EQUIPMENT,AUTOMOTIVE MAINTENANCE,AND REPAIR: ORGANIZATIONAL MAINTENANCE, COMMON NO. 1 LESS POWER	4910-00-754-0654	SC 4910-95CL- A74
4	O	TOOL KIT,GENERAL MECHANICS,AUTOMOTIVE	5180-00-177-7033	SC 5180-90- CL-N26
5	F	SHOP EQUIPMENT,WELDING: FIELD MAINTENANCE:	4940-00-357-7268	SC4940-95-CL- B19-HR
6	O	WRENCH,PIPE: ADJ JAW STYLE, 1-1/2 INCH TO 2-1/2 INCH	5120-00-277-1462	SC 4910-95CL- A74

**Section IV. REMARKS FOR
MAINTENANCE ALLOCATION CHART**

Reference code	REMARKS
<p align="center"> A B C D E F </p>	<p> Clean with Solvent at Element Change Replace Spring Tension Washer Operational Test Replace Gaskets Weld and Straighten Repair by Replacing Defective Components </p>

APPENDIX C

**OPERATOR'S, UNIT, AND DIRECT SUPPORT
MAINTENANCE REPAIR PARTS AND SPECIAL TOOLS LIST**

Section I. INTRODUCTION

1. **SCOPE.** This RPSTL lists and authorizes spares and repair parts; special tools; special test, measurement, and diagnostic equipment (TMDE); and other special support equipment required for performance of operator's, unit, and direct support maintenance of the 350 Gallon Per Minute Filter Separator. It authorizes the requisitioning, issue, and disposition of spares, repair parts and special tools as indicated by the source, maintenance and recoverability (SMR) codes.

2. **GENERAL.** In addition to this section, Introduction, this Repair Parts and Special Tools List is divided into the following sections:

a. **Section II. Repair Parts List.** A list of spares and repair parts authorized by this RPSTL for use in the performance of maintenance. This list also includes parts which must be removed for replacement of the authorized parts. Parts lists are composed of functional groups in ascending alphanumeric sequence, with the parts in each group listed in ascending figure and item number sequence. Bulk materials are listed in item name sequence. Items are shown in the associated illustration(s)/figure(s).

b. **Section III. Special Tools List.** A list of special tools, special TMDE, and other special support equipment authorized by this RPSTL (as indicated by Basis of Issue (BOI) information in DESCRIPTION AND USABLE ON CODE column) for the performance of maintenance.

c. **Section IV. Cross-References Indexes.** A list, in National Item Identification Number (NIIN) sequence, of all National stock numbered items appearing in the listing, followed by a list in alphanumeric sequence of all part numbers appearing in the listings. National stock numbers and part numbers are cross referenced to each illustration figure and item number appearance. The figure and item number index lists figure and item numbers in alphanumeric sequence and cross references NSN, CAGEC and part number.

3. **EXPLANATION OF COLUMNS (SECTIONS II AND III).**

a. **ITEM NO. (Column (1)).** Indicates the number used to identify items called out in the illustration.

b. **SMR Code (Column (2)).** The Source, Maintenance, and Recoverability (SMR) code is a 5-position code containing supply/requisitioning information, maintenance category authorization criteria, and disposition instruction, as shown in the following breakout:

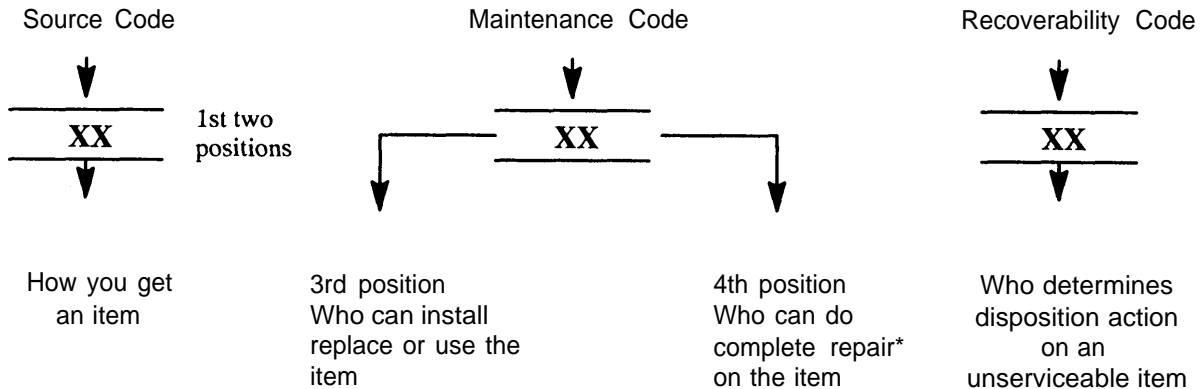

*Complete Repair: Maintenance capacity, capability, and authority to perform all corrective maintenance tasks of the "Repair" function in a use/user environment in order to restore serviceability to a failed item.

(1) Source Code. The source code tells you how to get an item needed for maintenance, repair, or overhaul of an end item/equipment. Explanations of source codes follows:

Source Code	Explanation
PA PB PC** PD PE PF PG	<p>Stocked items; use the applicable NSN to request/requisition items with these source codes. They are authorized to the category indicated by the code entered in the 3rd position of the SMR code.</p> <p>**NOTE: Items coded PC are subject to deterioration.</p>
KD KF KB	<p>Items with these codes are not to be requested/requisitioned individually. They are part of a kit which is authorized to the maintenance category indicated in the 3rd position of the SMR code. The complete kit must be requisitioned and applied.</p>
MO - (Made at Unit/AVUM Level) MF - (Made at DS/AVUM Level) MH - (Made at GS Level) ML - (Made at Specialized Repair Activity (SRA)) MD - (Made at Depot)	<p>Items with these codes are not to be requested/requisitioned individually. They must be made from bulk material which is identified by the part number in the DESCRIPTION and USABLE ON CODE (UOC) column and listed in the Bulk Material group of the repair parts list in this RPSTL. If the item is authorized to you by the 3rd position code of the SMR code, but the source code indicates it is made at a higher level, order the item from the higher level of maintenance.</p>
AO - (Assembled by Unit/AVUM Level) AF - (Assembled by DS/AVIM Level) AH - (Assembled by GS Category) AL - (Assembled by SRA) AD - (Assembled by Depot)	<p>Items with these codes are not to be requested/requisitioned individually. The parts that make up the assembled item must be requisitioned or fabricated and assembled at the level of maintenance indicated by the source code. If the 3rd position code of the SMR code authorizes you to replace the item, but the source code indicates the items are assembled at a higher level, order the item from the higher level of maintenance.</p>
XA -	Do not requisition "XA"-coded item. Order its next higher assembly. (Refer to the NOTE below.)
XB -	If an "XB" item is not available from salvage, order it using the CAGEC and part number given.
XC -	Installation drawing, diagram, instruction sheet, field service drawing, that is identified manufacturer's part number.
XD -	Item is not stocked. Order an "XD"-coded item through normal supply channels using the CAGEC and part number given, if no NSN is available.

NOTE

Cannibalization or controlled exchange, when authorized, may be used as a source of supply for items with the above source codes, except for those source coded "XA" or those aircraft support items restricted by requirements of AR 750-1.

(2) Maintenance Code Maintenance codes tell you the level(s) of maintenance authorized to USE and REPAIR support items. The maintenance codes are entered in the third and fourth positions of the SMR code as follows:

(a) The maintenance code entered in the third position tells you the lowest maintenance level authorized to remove, replace, and use an item. The maintenance code entered in the third position will indicate authorization to the following levels of maintenance.

Maintenance

Code	Application/Explanation
C -	Crew or operator maintenance done within unit/AVUM maintenance.
O -	Unit level/AVUM maintenance can remove, replace, and use the item.
F -	Direct support/AVIM maintenance can remove, replace, and use the item.
H -	General support maintenance can remove, replace, and use the item.
L -	Specialized repair activity can remove, replace, and use the item.
D -	Depot can remove, replace, and use the item.

(b) The maintenance code entered in the fourth position tells whether or not the item is to be repaired and identifies the lowest maintenance level with the capability to do complete repair (i.e., perform all authorized repair functions.)

NOTE

Some limited repair may be done on an item at a lower level of maintenance, if authorized by the Maintenance Allocation Chart and SMR codes.

Maintenance

Code	Application/Explanation
O -	Unit/AVUM is the lowest level that can do complete repair of the item.
F -	Direct support/AVIM is the lowest level that can do complete repair of the item.
H -	General Support is the lowest level that can do complete repair of the item.
L -	Specialized repair activity is the lowest level that can do complete repair of the item.
D -	Depot is the lowest level that can do complete repair of the item.
Z -	Nonreparable. No repair is authorized.
B -	No repair is authorized. No parts or special tools are authorized for the maintenance of a "B" coded item. However, the item may be reconditioned by adjusting, lubricating, etc., at the user level.

(3) Recoverability Code. Recoverability codes are assigned to items to indicate the disposition action on unserviceable items. The recoverability code is entered in the fifth position of the SMR Code as follows:

Recoverability

Codes	Application/Explanation
Z -	Nonreparable item. When unserviceable, condemn and dispose of the item at the level of maintenance shown in 3d position of SMR Code.
O -	Reparable item. When not economically reparable, condemn and dispose of the item at unit or AVUM level.
F -	Reparable item. When uneconomically reparable, condemn and dispose of the item at the direct support or AVIM level.
H -	Reparable item. When uneconomically reparable, condemn and dispose of the item at the general support level.
D -	Reparable item. When beyond lower level repair capability, return to depot. Condemnation and disposal of item not authorized below depot level.
L -	Reparable item. Condemnation and disposal not authorized below specialized repair activity (SRA).
A -	Item requires special handling or condemnation procedures because of specific reasons (e.g., precious metal content, high dollar value, critical material, or hazardous material). Refer to appropriate manuals/directives for specific instructions.
	c. <u>CAGEC (Column (3))</u> . The Commercial and Government Entity Code (CAGEC) is a 5-digit numeric code which is used to identify the manufacturer, distributor, or Government agency/activity that supplies the item.
	d. <u>PART NUMBER (Column (4))</u> . Indicates the primary number used by the manufacturer, (individual, company, firm, corporation, or Government activity), which controls the design and characteristics of the item by means of its engineering drawings, specifications, standards, and inspection requirements to identify an item or range of items.

NOTE

When you use an NSN to requisition an item, the item you receive may have a different part number from the number listed.

e. DESCRIPTION AND USABLE ON CODE (UOC) (Column (5)). This column includes the following information:

(1) The Federal item name and, when required, a minimum description to identify the item.

(2) Part numbers of bulk materials are referenced in this column in the line entry to be manufactured/fabricated.

(3) The statement "END OF FIGURE" appears just below the last item description in Column (5) for a given figure in both Section II and Section III.

f. QTY (Column (6)). The QTY (quantity per figure) column indicates the quantity of the item used in the breakout shown on the illustration/figure, which is prepared for a functional group, subfunctional group, or an assembly. A "V" appearing in this column instead of a quantity indicates that the quantity is variable and may vary from application to application.

4. EXPLANATION OF INDEX FORMAT AND COLUMNS (SECTION IV).

a. NATIONAL STOCK NUMBER (NSN) INDEX.

(1) STOCK NUMBER Column. This column lists the NSN in national item identification number (NIIN) sequence. The NIIN consists of the last nine digits of the NSN, i.e.

<u>NSN</u>
<u>5305-01-574-1467</u>
NIIN

When using this column to locate an item, ignore the first four digits of the NSN. Use the complete NSN (13 digits) when requisitioning items by stock number.

(2) FIG. Column. This column lists the number of the figure where the item is identified/located. The figures are in numerical order in Section II and Section III.

(3) ITEM Column. The item number identifies the item associated with the figure listed in the adjacent FIG. column. This item is also identified by the NSN listed on the same line.

b. PART NUMBER INDEX. Part numbers in this index are listed by part number in ascending alpha-numeric sequence (i.e., vertical arrangement of letter and number combination which places the first letter or digit of each group in order A through Z, followed by the numbers 0 through 9, and each following letter or digit in like order).

(1) CAGEC Column. The Commercial and Government Entity Code (CAGEC) is a 5-digit numeric code used to identify the manufacturer, distributor, or Government agency/activity that supplies the item.

(2) PART NUMBER Column. Indicates the primary number used by the manufacturer (individual, firm, corporation, or Government activity), which controls the design and characteristics of the item by means of its engineering drawings, specifications, standards, and inspection requirements to identify an item or range of items.

(3) STOCK NUMBER Column. This column lists the NSN for the associated part number and manufacturer identified in the PART NUMBER and CAGEC columns to the left.

(4) FIG. Column. This column lists the number of the figure where the item is identified/located in Section II and Section III.

(5) ITEM Column. The item number is that number assigned to the item as it appears in the figure referenced in adjacent figure number column.

c. FIGURE AND ITEM NUMBER INDEX.

(1) FIG. Column. This column lists the number of the figure where the item is identified/located in Section II and Section III.

(2) ITEM Column. The item number is that number assigned to the item as it appears in the figure referenced in the adjacent figure number column.

(3) STOCK NUMBER Column. This column lists the NSN for the item.

(4) CAGEC Column. The Commercial and Government Entity Code (CAGEC) is a 5-digit numeric code used to identify the manufacturer, distributor, or Government agency/activity that supplies the item.

(5) PART NUMBER Column. Indicates the primary number used by the manufacturer (individual, firm, corporation, or Government activity), which controls the design and characteristics of the item by means of its engineering drawings, specifications, standards, and inspection requirements to identify an item or range of items.

5. SPECIAL INFORMATION

a. USABLE ON CODE. The usable on code appears in the lower left corner of the Description Column heading. Usable on codes are shown as "UOC:..." in the Description Column (justified left) on the last line of the applicable item description/nomenclature. Uncoded items are applicable to all models.

b. FABRICATION INSTRUCTIONS. Bulk materials required to manufacture items are listed in the Bulk Material Functional Group of this RPSTL. Part numbers for bulk materials are also referenced in the description column of the line entry for the item to be manufactured/fabricated. Detailed fabrication instructions for items source coded to be manufactured or fabricated are found in Appendix I.

c. INDEX NUMBERS. Items which have the word BULK in the figure column will have an index number shown in the item number column. This index number is a cross-reference between the National Stock Number/Part Number Index and the bulk material list in Section II.

d. ASSOCIATED PUBLICATIONS. See Appendix A for a list of associated publications.

6. HOW TO LOCATE REPAIR PARTS.

a. When National Stock Numbers or Part Numbers are NOT Known.

(1) First. Using the table of contents, determine the assembly or subassembly group to which the item belongs. This is necessary since figures are prepared for assembly groups and subassembly groups, and listings are divided into the same groups.

(2) Second. Find the figure covering the assembly group or subassembly group to which the item belongs.

(3) Third. Identify the item on the figure and use the Figure and Item Number Index to find the NSN.

b. When National Stock Number or Part Number is Known.

(1) First. Using the of National Stock Number and Part Number Indexes find the pertinent National Stock Number or Part Number. The NSN index is in National Item Identification Number (NIIN) sequence (see paragraph 4.a). The part numbers in the Part Number index are listed in ascending alphanumeric sequence (see paragraph 4.b). Both indexes cross-reference you to the illustration/figure and item number of the item you are looking for.

(2) Second. Turn to the figure and item number, verify that the item is the one you are looking for, then locate the item number in the repair parts list for the figure.

7. ABBREVIATIONS. Abbreviations used in this manual are listed in MIL-STD-12.

APPENDIX C

**OPERATOR'S, UNIT, AND DIRECT SUPPORT
MAINTENANCE REPAIR PARTS AND SPECIAL TOOLS LIST**

Section 1. INTRODUCTION

1. SCOPE. This RPSTL lists and authorizes spares and repair parts; special tools; special test, measurement, and diagnostic equipment (TMDE); and other special support equipment required for performance of operator's, unit, and direct support maintenance of the 350 Gallon Per Minute Filter Separator. It authorizes the requisitioning, issue, and disposition of spares, repair parts and special tools as indicated by the source, maintenance and recoverability (SMR) codes.
2. GENERAL. In addition to this section, Introduction, this Repair Parts and Special Tools List is divided into the following sections:
 - a. Section II. Repair Parts List. A list of spares and repair parts authorized by this RPSTL for use in the performance of maintenance. This list also includes parts which must be removed for replacement of the authorized parts. Parts lists are composed of functional groups in ascending alphanumeric sequence, with the parts in each group listed in ascending figure and item number sequence. Bulk materials are listed in item name sequence. Items are shown in the associated illustration(s)/figure(s).
 - b. Section II. Special Tools List. A list of special tools, special TMDE, and other special support equipment authorized by this RPSTL (as indicated by Basis of Issue (BOI) information in DESCRIPTION AND USABLE ON CODE column) for the performance of maintenance.
 - c. Section IV. Cross-References Indexes. A list, in National Item Identification Number (NIIN) sequence, of all National stock numbered items appearing in the listing, followed by a list in alphanumeric sequence of all part numbers appearing in the listings. National stock numbers and part numbers are cross referenced to each illustration figure and item number appearance. The figure and item number index lists figure and item numbers in alphanumeric sequence and cross references NSN, CAGEC and part number.
3. EXPLANATION OF COLUMNS (SECTIONS II AND III).
 - a. ITEM NO. (Column 1). Indicates the number used to identify items called out in the illustration.
 - b. SMR Code (Column 2). The Source, Maintenance, and Recoverability (SMR) code is a 5-position code containing supply/requisitioning information, maintenance category authorization criteria, and disposition instruction, as shown in the following breakout:

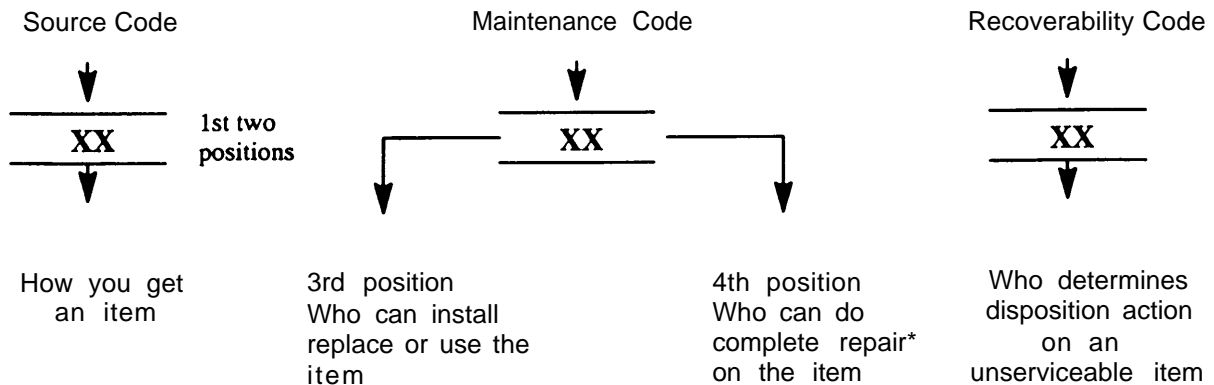

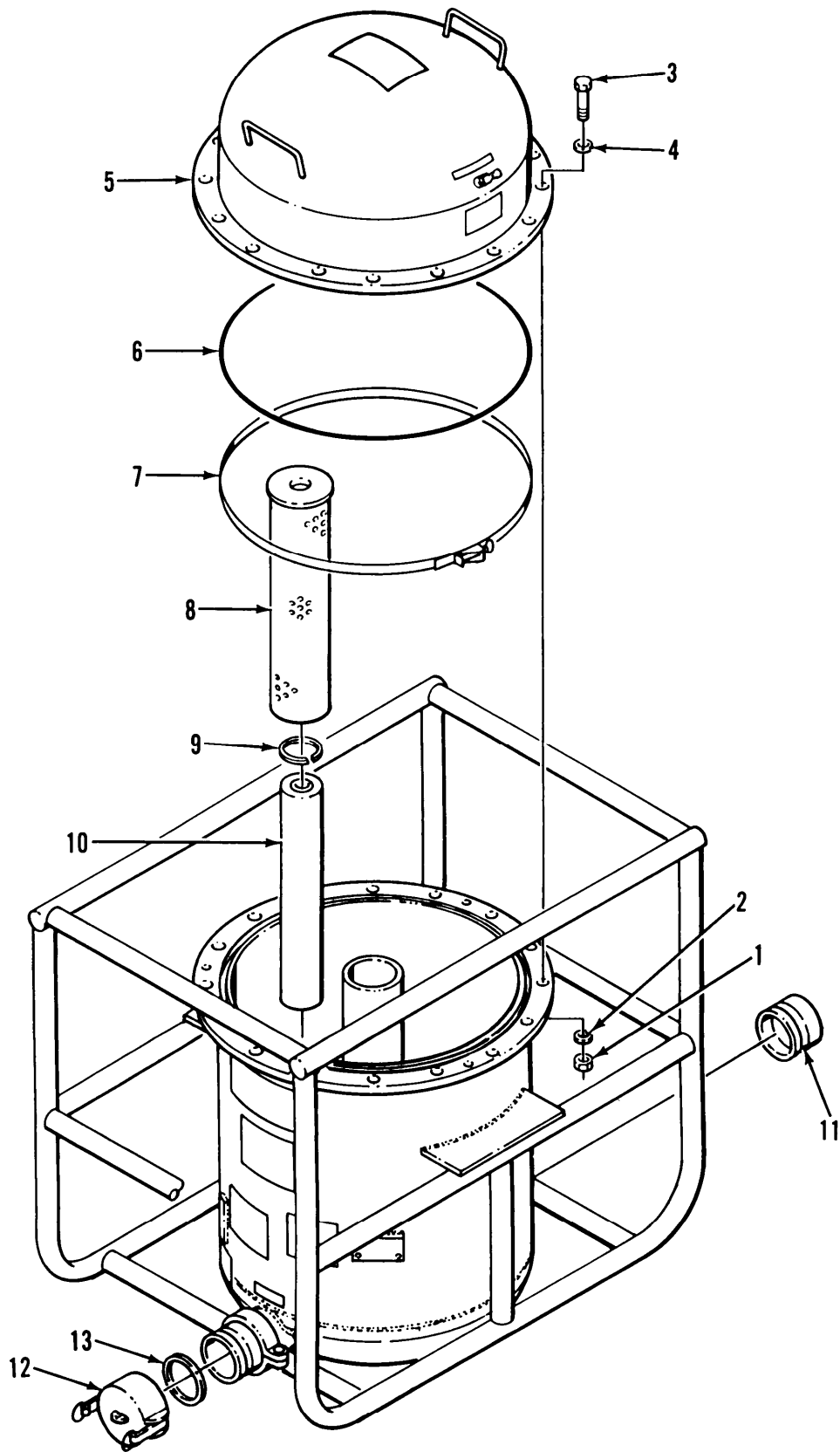

Figure 1. Cover, Canisters and Elements

(1) ITEM NO	(2) SMR CODE	(3) CAGEC	(4) PART NUMBER	(5) DESCRIPTION AND USABLE ON CODES (UOC)	(6) QTY
GROUP 01 FILTER SEPARATOR					
FIG. 1 COVER, CANISTERS AND ELEMENTS					
1	PAOZZ	96906	MS51968-20	NUT, PLAIN, HEXAGON	16
2	PAOZZ	96906	MS35338-50	WASHER, LOCK	16
3	PAOZZ	96906	MS90726-167	SCREW, CAP, HEXAGON H	16
4	PAOZZ	96906	MS27183-21	WASHER, FLAT	16
5	XBOZZ	97403	13217E9322	COVER, TANK	1
6	PAOZZ	97403	13217E9325-1	PACKING, PREFORMED	1
7	PAOZZ	00624	820-50	CLAMP, BAND	1
8	PAOOZ	97403	13216E2773	FILTER ELEMENT, FLUI	18
9	PAOZZ	97403	13216E2774	.WASHER, SPRING TENSI	1
10	PAOZZ	81349	MIL-F-52308	FILTER ELEMENT	18
11	PAOZZ	96906	MS27029-17	PLUG, QUICK DISCONNE	1
12	PAOZZ	96906	MS27028-17	CAP, QUICK DISCONNEN	1
13	PAOZZ	96906	MS27030-9	.GASKET	1

END OF FIGURE

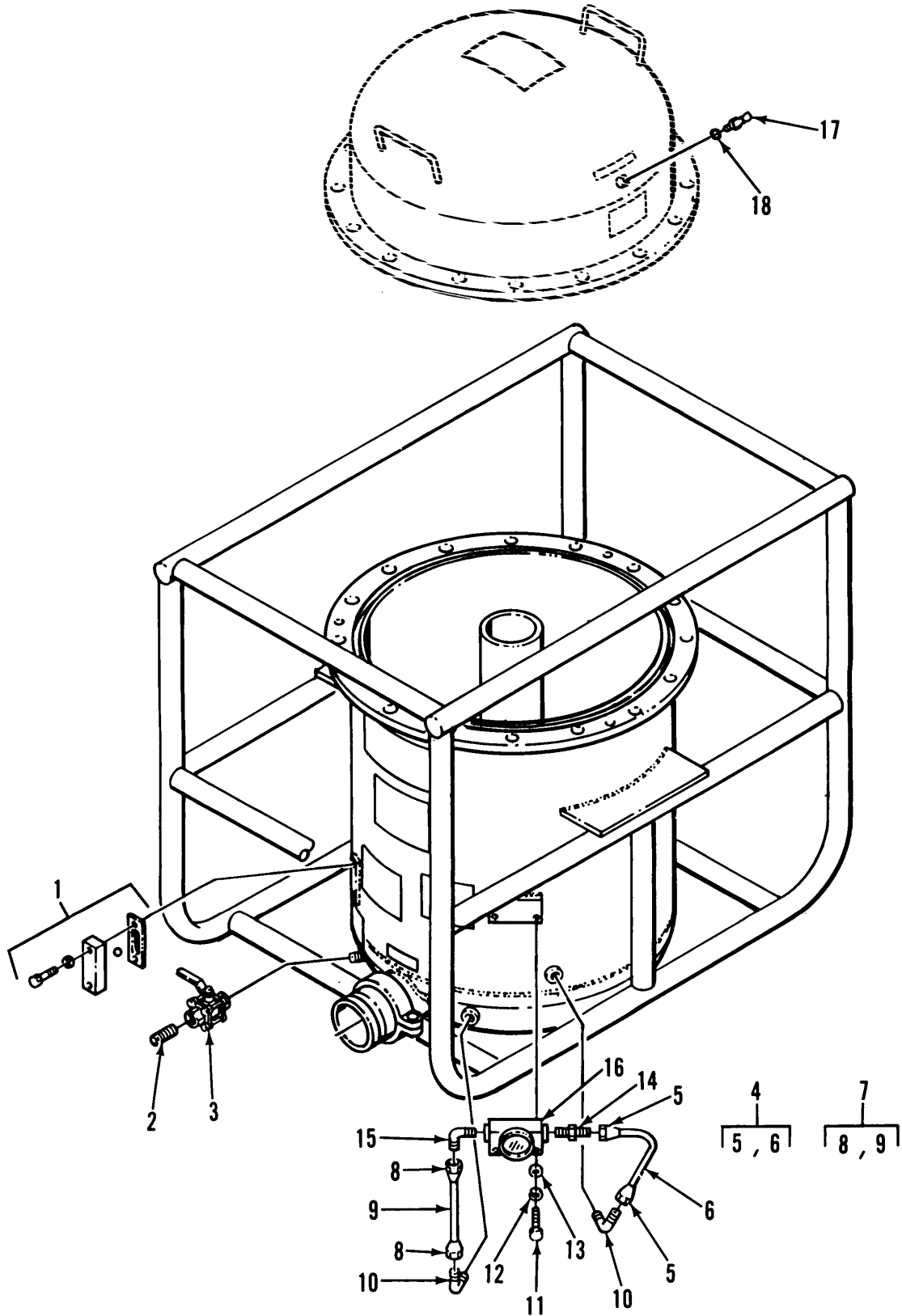

Figure 2. Gauges, Valves and Lines

(1) ITEM NO	(2) SMR CODE	(3) CAGEC	(4) PART NUMBER	(5) DESCRIPTION AND USABLE ON CODES (UOC) GROUP 01 FILTER SEPARATOR FIG. 2 GAUGES, VALVES AND ELEMENTS	(6) QTY
1	PAOZO	97403	13217E5360	GLASS, LIQUID SIGHT	1
2	XBOZZ	51744	13217E9320-9	NIPPLE, PIPE	1
3	PAOZZ	9S781	1000WOG-1NPT	VALVE, BALL TYPE	1
4	AFOZZ	97403	13217E5365-8	TUBE ASSEMBLY	1
5	PAFZZ	88044	AN817-5D	.NUT, TUBE COUPLING	2
6	MFFZZ	51744	13217E5365-1-8	.TUBE, DRAWN, SEAMLESS MAKE FROM BULK, P/N 5052-0 (CAGE 81346), 7.68 IN. REQD	1
7	AFOZZ	97403	13217E5365-3	TUBE ASSEMBLY	1
8	PAFZZ	88044	AN817-5D	.NUT, TUBE COUPLING	2
9	MFFZZ	51744	13217E5365-1-3	.TUBE, DRAWN, SEAMLESS MAKE FROM BULK, P/N 5052-0 (CAGE 81346), 4.82 IN. REQD	1
10	PAOZZ	96906	MS20822-5-4D	ELBOW, PIPE TO TUBE	2
11	PAOZZ	96906	MS35206-285	SCREW, MACHINE	2
12	PAOZZ	96906	MS35338-44	WASHER, LOCK	2
13	PAOZZ	81352	AN960-416L	WASHER, FLAT	2
14	PAOZZ	81352	AN816-5D	ADAPTER, STRAIGHT	1
15	PAOZZ	96906	MS20822-5D	ELBOW, PIPE TO TUBE	1
16	PAOZZ	30839	1201-PG-2-2	GAGE, DIFF PRESSURE	1
17	PAOOZ	97403	13216E2798	VALVE, SAFETY RELIEF	1
18	PAOZZ	96906	MS29513-010	.PACKING, PREFORMED	1

END OF FIGURE

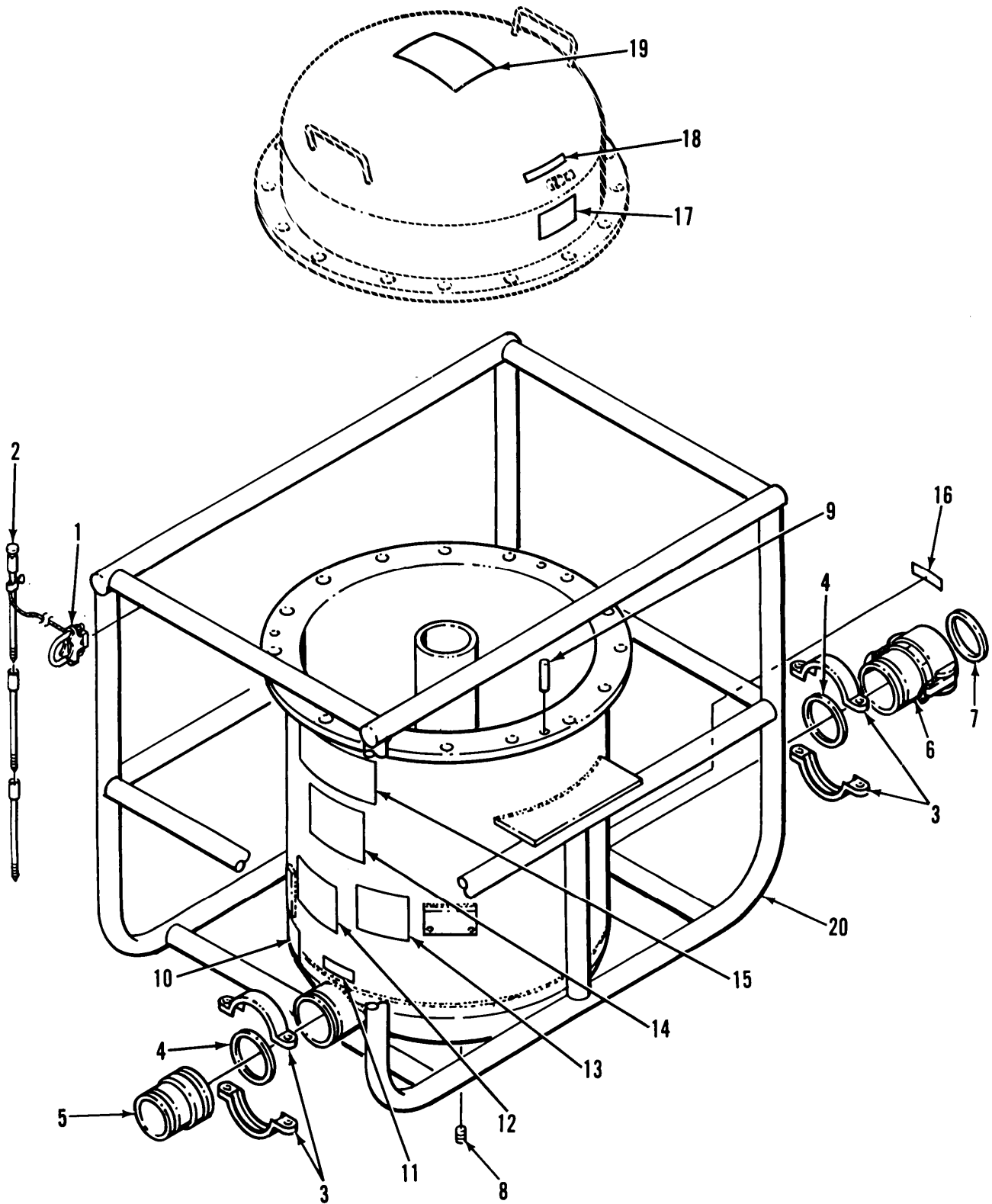

Figure 3. Tank and Frame

(1) ITEM NO	(2) SMR CODE	(3) CAGEC	(4) PART NUMBER	(5) DESCRIPTION AND USABLE ON CODES (UOC) GROUP 01 FILTER SEPARATOR FIG. 3 TANK AND FRAME	(6) QTY
1	PAOZZ	97403	13217E9339	CLAMP,ELECTRICAL	1
2	PAOZZ	81348	W-R-550	ROD,GROUND	1
3	XBOZZ	81349	M103871C09	COUPLING,ASSY	2
4	PAOZZ	81349	M103873C09	.GASKET	1
5	PBOZZ	97403	13217E9336	COUPLING HALF,QUICK	1
6	PBOZZ	97403	13217E9327	COUPLING HALF,QUICK	1
7	PAOZZ	96906	MS27030-9	.GASKET	1
8	PAOZZ	96906	MS20913-4D	PLUG,PIPE	1
9	PBOZZ	96906	MS16555-677	PIN,STRAIGHT,HEADLE	2
10	XBOZZ	97403	13228E1865	PLATE,INSTRUCTION	1
11	XBOZZ	97403	13216E2766	PLATE,DATA	1
12	XBOZZ	97403	13216E2768	PLATE,INSTRUCTION	1
13	XBOZZ	97403	13219E9750	PLATE,INSTRUCTION	1
14	XBOZZ	97403	13217E5357-2	PLATE,IDENTIFICATIO	1
15	XBOZZ	97403	13217E9323	PLATE,INSTRUCTION	1
16	XBOZZ	97403	13216E2767	PLATE,INSTRUCTION	1
17	XBOZZ	97403	13228E1866	PLATE,INSTRUCTION	1
18	XBOZZ	97403	13228E1864	PLATE,INSTRUCTION	1
19	XBOZZ	97403	13228E1863	PLATE,INSTRUCTION	1
20	XAFZZ	97403	13217E9321	TANK,FILTER/SEPARAT	1

END OF FIGURE

1
2 — 9

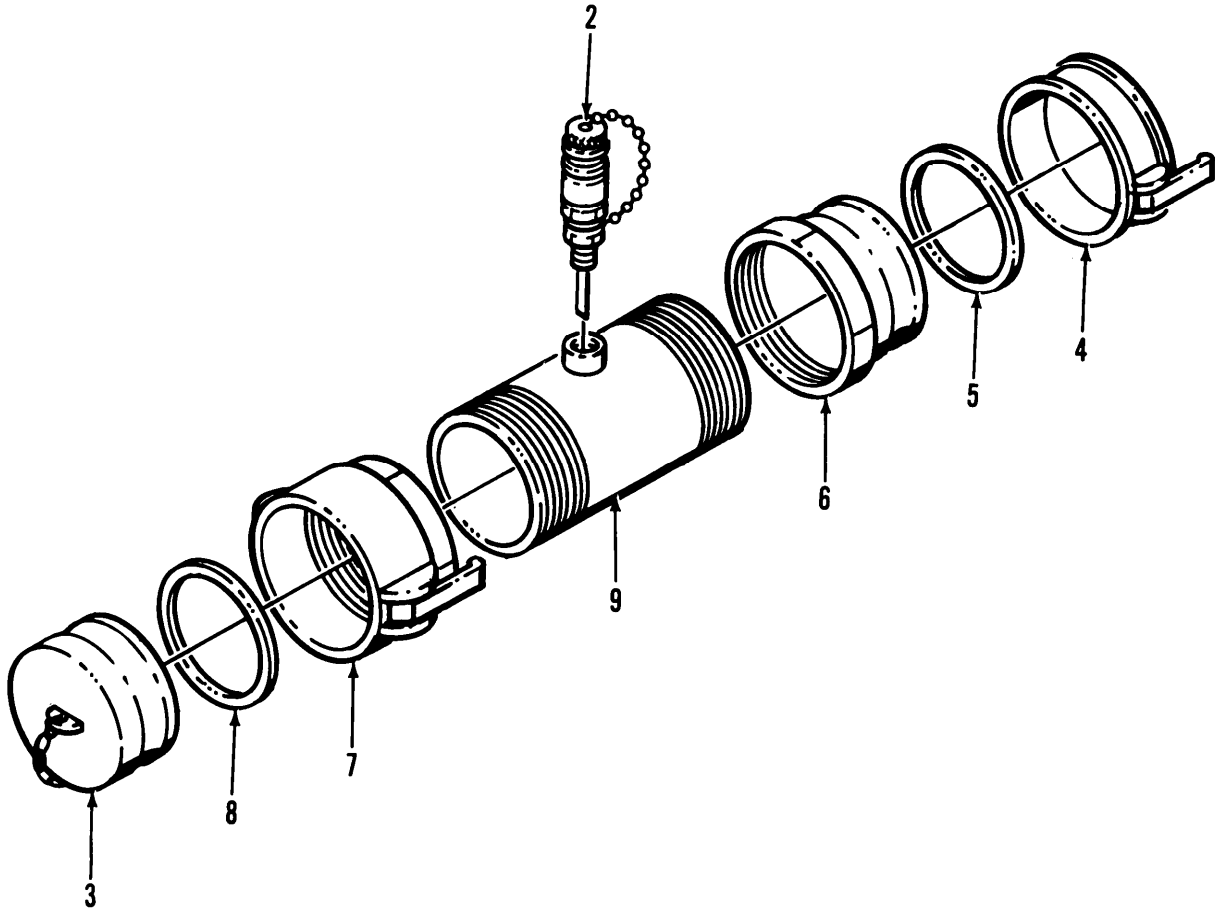

Figure 4. Water Detector Adapter

(1) ITEM NO	(2) SMR CODE	(3) CAGEC	(4) PART NUMBER	(5) DESCRIPTION AND USABLE ON CODES (UOC)	(6) QTY
GROUP 02 WATER DETECTOR ADAPTER					
FIG. 4 WATER DETECTOR ADAPTER					
1	PAOOZ	97403	13220E9406-2	ADAPTER ASSEMBLY,WA	1
2	PAOZZ	97403	13220E9914-2	PROBE ASSEMBLY,WATE	1
3	PAOZZ	96906	MS27029-17	PLUG,QUICK DISCONNE	1
4	PAOZZ	96906	MS27028-17	CAP,QUICK DISCONNEC	1
5	PAOZZ	96906	MS27030-9	.GASKET	1
6	PAOZZ	96906	MS27020-17	COUPLING HALF,QUICK	1
7	PAOZZ	96906	MS27024-17	COUPLING HALF,QUICK	1
8	PAOZZ	96906	MS27030-9	.GASKET	1
9	XBOZZ	51744	13220E9406-2-4	NIPPLE,PIPE	1
END OF FIGURE					

TM10-4330-235-13&P

SECTION II

(1) ITEM NO	(2) SMR CODE	(3) CAGEC	(4) PART NUMBER	(5) DESCRIPTION AND USABLE ON CODES (UOC)	(6) QTY
1	PAFZZ	81346	5052-0	GROUP 03 BULK MATERIALS FIG. BULK TUBE, DRAWN, SEAMLESS END OF FIGURE	1

BULK-1/(BULK-2 BLANK)

SECTION III

TM10-4330-235-13&P

SPECIAL TOOLS LIST

(NOT APPLICABLE)

CROSS-REFERENCE INDEXES

NATIONAL STOCK NUMBER INDEX

STOCK NUMBER	FIG.	ITEM	STOCK NUMBER	FIG.	ITEM
4730-00-088-9286	4	7			
4330-00-112-0256	1	8			
4730-00-163-4669	3	6			
4730-00-167-6822	3	5			
6680-00-197-4941	2	1			
5330-00-248-3835	2	18			
4730-00-278-3678	2	15			
4730-00-278-4684	2	10			
5975-00-296-5324	3	2			
5330-00-401-4805	1	6			
4820-00-407-2581	2	17			
5310-00-492-2143	1	9			
5310-00-582-5965	2	12			
4730-00-639-9869	2	5			
	2	8			
4730-00-640-6156	1	12			
	4	4			
4730-00-640-6188	1	11			
	4	3			
5305-00-726-2554	1	3			
5310-00-763-8905	1	1			
5310-00-820-6653	1	2			
5310-00-823-8803	1	4			
4730-00-840-0796	4	6			
5315-00-889-2767	3	9			
5330-00-899-4509	1	13			
	3	7			
	4	5			
	4	8			
5305-00-988-1171	2	11			
4930-01-013-7589	4	2			
4930-01-013-7590	4	1			
5999-01-032-4145	3	1			

CROSS-REFERENCE INDEXES

CAGEC	PART NUMBER	PART NUMBER INDEX STOCK NUMBER	FIG.	ITEM
81352	AN816-5D		2	14
88044	AN817-5D	4730-00-639-9869	2	5
			2	8
81352	AN960-416L		2	13
81349	MIL-F-52308		1	10
96906	MS16555-677	5315-00-889-2767	3	9
96906	MS20822-5-4D	4730-00-278-4684	2	10
96906	MS20822-5D	4730-00-278-3678	2	15
96906	MS20913-4D		3	8
96906	MS27020-17	4730-00-840-0796	4	6
96906	MS27024-17	4730-00-088-9286	4	7
96906	MS27028-17	4730-00-640-6156	1	12
			4	4
96906	MS27029-17	4730-00-640-6188	1	11
			4	3
96906	MS27030-9	5330-00-899-4509	1	13
			3	7
			4	5
			4	8
96906	MS27183-21	5310-00-823-8803	1	4
96906	MS29513-010	5330-00-248-3835	2	18
96906	MS35206-285	5305-00-988-1171	2	11
96906	MS35338-44	5310-00-582-5965	2	12
96906	MS35338-50	5310-00-820-6653	1	2
96906	MS51968-20	5310-00-763-8905	1	1
96906	MS90726-167	5305-00-726-2554	1	3
81349	M103871C09		3	3
81349	M103873C09		3	4
81348	W-R-550	5975-00-296-5324	3	2
9S781	1000WOG-1NPT		2	3
30839	1201-PG-2-2		2	16
97403	13216E2766		3	11
97403	13216E2767		3	16
97403	13216E2768		3	12
97403	13216E2773	4330-00-112-0256	1	8
97403	13216E2774	5310-00-492-2143	1	9
97403	13216E2798	4820-00-407-2581	2	17
97403	13217E5357-2		3	14
97403	13217E5360	6680-00-197-4941	2	1
51744	13217E5365-1-3		2	9
51744	13217E5365-1-8		2	6
97403	13217E5365-3		2	7
97403	13217E5365-8		2	4
51744	13217E9320-9		2	2
97403	13217E9321		3	20
97403	13217E9322		1	5
97403	13217E9323		3	15
97403	13217E9325-1	5330-00-401-4805	1	6
97403	13217E9327	4730-00-163-4669	3	6
97403	13217E9336	4730-00-167-6822	3	5
97403	13217E9339	5999-01-032-4145	3	1

CROSS-REFERENCE INDEXES

CAGEC	PART NUMBER	PART NUMBER INDEX STOCK NUMBER	FIG.	ITEM
97403	13219E9750		3	13
97403	13220E9406-2	4930-01-013-7590	4	1
51744	13220E9406-2-4		4	9
97403	13220E9914-2	4930-01-013-7589	4	2
97403	13228E1863		3	19
97403	13228E1864		3	18
97403	13228E1865		3	10
97403	13228E1866		3	17
81346	5052-0		BULK	1
00624	820-50		1	7

CROSS-REFERENCE INDEXES

FIG.	ITEM	FIGURE AND ITEM NUMBER INDEX		PART NUMBER
		STOCK NUMBER	CAGEC	
BULK	1		81346	5052-0
1	1	5310-00-763-8905	96906	MS51968-20
1	2	5310-00-820-6653	96906	MS35338-50
1	3	5305-00-726-2554	96906	MS90726-167
1	4	5310-00-823-8803	96906	MS27183-21
1	5		97403	13217E9322
1	6	5330-00-401-4805	97403	13217E9325-1
1	7		00624	820-50
1	8	4330-00-112-0256	97403	13216E2773
1	9	5310-00-492-2143	97403	13216E2774
1	10		81349	MIL-F-52308
1	11	4730-00-640-6188	96906	MS27029-17
1	12	4730-00-640-6156	96906	MS27028-17
1	13	5330-00-899-4509	96906	MS27030-9
2	1	6680-00-197-4941	97403	13217E5360
2	2		51744	13217E9320-9
2	3		9S781	1000WOG-1NPT
2	4		97403	13217E5365-8
2	5	4730-00-639-9869	88044	AN817-5D
2	6		51744	13217E5365-1-8
2	7		97403	13217E5365-3
2	8	4730-00-639-9869	88044	AN817-5D
2	9		51744	13217E5365-1-3
2	10	4730-00-278-4684	96906	MS20822-5-4D
2	11	5305-00-988-1171	96906	MS35206-285
2	12	5310-00-582-5965	96906	MS35338-44
2	13		81352	AN960-416L
2	14		81352	AN816-5D
2	15	4730-00-278-3678	96906	MS20822-5D
2	16		30839	1201-PG-2-2
2	17	4820-00-407-2581	97403	13216E2798
2	18	5330-00-248-3835	96906	MS29513-010
3	1	5999-01-032-4145	97403	13217E9339
3	2	5975-00-296-5324	81348	W-R-550
3	3		81349	M103871C09
3	4		81349	M103873C09
3	5	4730-00-167-6822	97403	13217E9336
3	6	4730-00-163-4669	97403	13217E9327
3	7	5330-00-899-4509	96906	MS27030-9
3	8		96906	MS20913-4D
3	9	5315-00-889-2767	96906	MS16555-677
3	10		97403	13228E1865
3	11		97403	13216E2766
3	12		97403	13216E2768
3	13		97403	13219E9750
3	14		97403	13217E5357-2
3	15		97403	13217E9323
3	16		97403	13216E2767
3	17		97403	13228E1866
3	18		97403	13228E1864
3	19		97403	13228E1863

CROSS-REFERENCE INDEXES

FIG.	ITEM	FIGURE AND ITEM NUMBER INDEX		PART NUMBER
		STOCK NUMBER	CAGEC	
3	20		97403	13217E9321
4	1	4930-01-013-7590	97403	13220E9406-2
4	2	4930-01-013-7589	97403	13220E9914-2
4	3	4730-00-640-6188	96906	MS27029-17
4	4	4730-00-640-6156	96906	MS27028-17
4	5	5330-00-899-4509	96906	MS27030-9
4	6	4730-00-840-0796	96906	MS27020-17
4	7	4730-00-088-9286	96906	MS27024-17
4	8	5330-00-899-4509	96906	MS27030-9
4	9		51744	13220E9406-2-4

APPENDIX D COMPONENTS OF END ITEM AND BASIC ISSUE ITEMS LISTS

Section I. INTRODUCTION

D-1. SCOPE

This appendix lists components of end item and basic issue items for the Filter/Separator to help you inventory items required for safe and efficient operation.

D-2. GENERAL

The Components of End Item and Basic Issue Items Lists are divided into the following sections:

a. Section II, Components of End Item. This listing is for informational purposes only, and is not authority to requisition replacements. These items are part of the end item, but are removed and separately packaged for transportation or shipment. As part of the end item, these items must be with the end item whenever it is issued or transferred between property accounts. Illustrations are furnished to assist you in identifying the items.

b. Section III. Basic Issue Items. These are the minimum essential items required to place the Filter/Separator in operation, to operate it, and to perform emergency repairs. Although shipped separately packaged, BII must be with the Filter/Separator during operation and whenever it is transferred between property accounts. The illustrations will assist you with hard-to-identify items. This manual is your authority to request/requisition replacement BII, based on TOE/MTOE authorization of the end item.

D-3. EXPLANATION OF COLUMNS

The following provides an explanation of columns found in the tabular listings:

- a. Column (1) - Illustration Number (Illus Number). This column indicates the number of the illustration in which the item is shown,
- b. Column (2) - National Stock Number. Indicates the National stock number assigned to the item and will be used for requisitioning purposes.
- c. Column (3) - Description. Indicates the Federal item name and, if required, a minimum description to identify and locate the item. The last line for each item indicates the FSCM (in parentheses) followed by the part number.
- d. Column (4) - Unit of Measure (U/M). Indicates the measure used in performing the actual operational/maintenance function. This measure is expressed by a two-character alphabetical abbreviation (e.g., ea, in, pr).
- e. Column (5) - Quantity required (Qty rqr). Indicates the quantity of the item authorized to be used with/on the equipment.

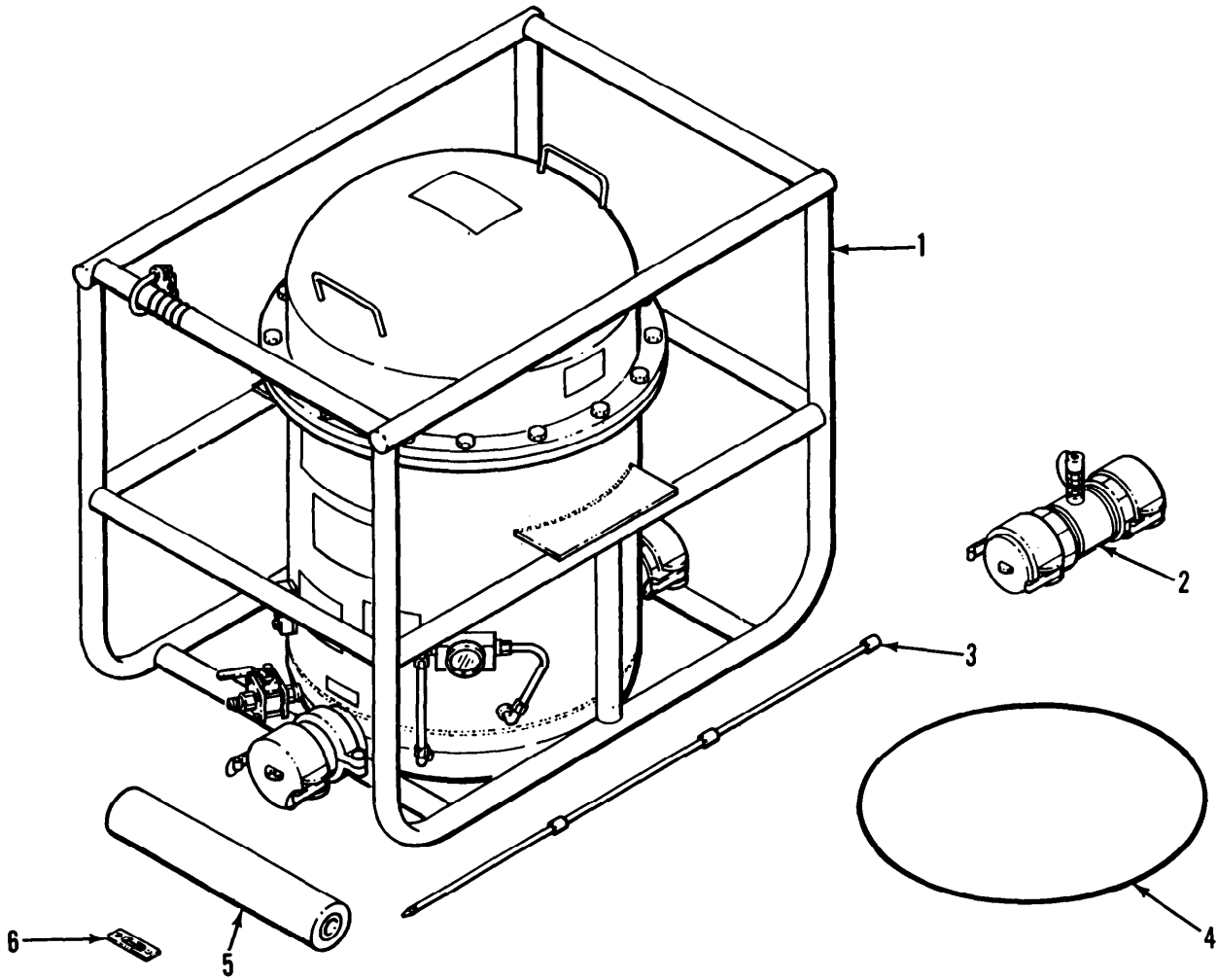

Section II. COMPONENTS OF END ITEM

(1) Illus/ Item No	(2) National Stock Number	(3) Description CAGE and Part Number	Usable On Code	(4) U/M	(5) Qty rqr
1	4330-00-177-8485	Filter/Separator (97403) 13217E9320		Ea	1
2	4930-01-013-7590	Water Detector Kit (97403) 13220E9406-2		Ea	1
3	5975-00-296-5324	Rod, Ground (81348) W-R-550		Ea	1
4	5330-00-401-4805	ON BOARD SPARES: Packing, Preformed (97403) 13217E9325-1		Ea	1
5	4330-00-983-0998	Filter Element (81349) MIL-F-52308		Ea	18
6	5330-00-235-4716	Gasket, Sight Gage (97403) 13217E 5363		Ea	1

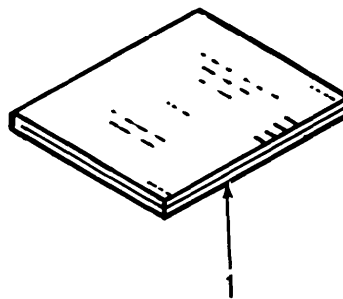

Section III. BASIC ISSUE ITEMS

(1) Illus Number	(2) National Stock Number	(3) Description CAGE and Part Number	(4) Usable On Code U/M	(5) Qty rqr
1		Technical Manual TM10-4330-235-13&P	Ea	1

APPENDIX E
ADDITIONAL AUTHORIZATION LIST

Not Applicable

APPENDIX F
EXPENDABLE/DURABLE SUPPLIES AND MATERIALS LIST

Section I. INTRODUCTION

F-1. SCOPE

This appendix lists expendable supplies and materials you will need to operate and maintain the Filter Separator. This listing is for informational purposes only and is not authority to requisition the listed items. These items are authorized to you by CTA 50-970, Expendable/Durable Items (Except Medical, Class V, Repair Parts, and Heraldic Items), or CTA 8-100, Army Medical Department Expendable/Durable Items.

F-2. EXPLANATION OF COLUMNS

a. Column (1) - Item number. This number is assigned to the entry in the listing and is referenced in the narrative instructions to identify the material.

b. Column (2) - Level. This column identifies the lowest level of maintenance that requires the listed item.

- O - Unit Maintenance
- F - Direct Support Maintenance

c. Column (3) - National Stock Number. This is the National Stock number assigned to the item; use it to request or requisition the item.

d. Column (4) - Description. Indicates the Federal item name and, if required, a description to identify the item. The last line for each item indicates the Federal Supply Code for Manufacturer (FSCM) in parentheses followed by the part number.

e. Column (5) - Unit of Measure (U/M). Indicates the measure used in performing the actual maintenance function. This measure is expressed by a two-character alphabetical abbreviation (e.g., ea, in, pr). If the unit of measure differs from the unit of issue, requisition the lowest unit of issue that will satisfy your requirements.

SECTION II. EXPENDABLE SUPPLIES AND MATERIALS LIST

(1)	(2)	(3)	(4)	(5)
ITEM NUMBER	LEVEL	NATIONAL STOCK NUMBER	DESCRIPTION	U/M
1	O	6950-00-281-1985	DRY CLEANING SOLVENT	GAL
2	O	6850-00-880-7616	SILICONE COMPOUND (81349) MIL-S-8660	EA
3	O	8030-00-543-4384	SEALING COMPOUND (81349) MIL-S-7916	LB
4	O	8040-00-262-9011	ADHESIVE, RUBBER BASE, GENERAL PURPOSE (81349) MMM-A-1617, TYPE III	EA
5	O	7920-00-205-1711	RAGS	BE
6	O	8415-00-577-4091	GLOVES, SMALL	PR
7	O	8415-00-577-4092	GLOVES, MEDIUM	PR
8	O	8415-00-577-4093	GLOVES, LARGE	PR

APPENDIX G
TORQUE LIMITS
TIGHTENING METAL FASTENERS

When torquing a fastener, select a wrench whose range fits the required torque value. A torque wrench is most accurate from 25% to 75% of its stated range. A wrench with a stated range of 0 to 100 will be most accurate from 25 to 75 Pound Feet. The accuracy of readings will decrease as you approach 0 Pound Feet or 100 Pound Feet.

APPENDIX H
MANDATORY REPLACEMENT PARTS

H-1. SCOPE

THIS APPENDIX LISTS ALL MANDATORY REPLACEMENT PARTS REFERENCED IN THE TASK SETUPS IN THIS MANUAL.

(1) ITEM NUMBER	(2) PART NUMBER	(3) NOMENCLATURE
1	13217E9325-1	PACKING, PREFORMED
2	MS35338-50	WASHER, LOCK
3	MIL-F-52308	FILTER ELEMENT
4	13217E2774	WASHER, SPRING TENSION
5	13217E5363	GASKET

APPENDIX I
MANUFACTURED ITEMS

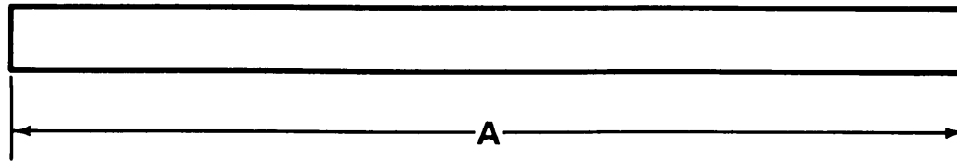

MATERIAL	
DESCRIPTION	PART NO. & CAGE
TUBE, DRAWN, SEAMLESS, .31 OD X .035 WALL	5052-6 (81346)

PROCEDURE:

CUT TUBING TO LENGTH SHOWN IN TABLE

PART NUMBER	LENGTH "A"
13217E5365-1-8	7.68
13217E5365-1-3	4.82

NOTE:

DIMENSIONS ARE IN INCHES

By Order of the Secretary of the Army:

Official:

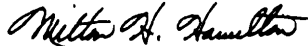
MILTON H. HAMILTON
*Administrative Assistant to the
Secretary of the Army*

03980

GORDON R. SULLIVAN
*General, United States Army
Chief of Staff*

DISTRIBUTION:

To be distributed in accordance with DA Form 12-25-E, block no. 6038, requirements for
TM 10-4330-235-13&P.

RECOMMENDED CHANGES TO EQUIPMENT TECHNICAL PUBLICATIONS



THEN... JOT DOWN THE DOPE ABOUT IT ON THIS FORM. CAREFULLY TEAR IT OUT, FOLD IT AND DROP IT IN THE MAIL!

SOMETHING WRONG WITH THIS PUBLICATION?

FROM: (PRINT YOUR UNIT'S COMPLETE ADDRESS)
PFC JOHN DOE
COA, 3d ENGINEER BN
FT. LEONARDWOOD, WA 63108
 DATE SENT

PUBLICATION NUMBER: **TM 10-4330-236-13&P**
 PUBLICATION DATE: **31 MARCH 1993**
 PUBLICATION TITLE OPERATOR, UNIT AND DIRECT SUPPORT RPSTL FILTER SEPARATOR, LIQUID FUEL

BE EXACT PIN-POINT WHERE IT IS

PAGE NO	PARA-GRAPH	FIGURE NO	TABLE NO
6	2-1 a		
B1		4-3	
125	line 20		

IN THIS SPACE TELL WHAT IS WRONG AND WHAT SHOULD BE DONE ABOUT IT:

In line 6 of paragraph 2-1a the manual states the engine has 6 Cylinders. The engine on my set only has 4 Cylinders. Change the manual to show 4 Cylinders.

Callout 16 on figure 4-3 is pointing at a bolt. In key to figure 4-3, item 16 is called a shim - Please correct one or the other.

I ordered a gasket, item 19 on figure B-16 by NSN 2 910-05-762-3001. I got a gasket but it doesn't fit. Supply says I got what I ordered, so the NSN is wrong. Please give me a good NSN

PRINTED NAME, GRADE OR TITLE AND TELEPHONE NUMBER
JOHN DOE, PFC (262) 317.7111

SIGN HERE **John Doe**
JOHN DOE

DA FORM 2028-2 1 JUL 79

PREVIOUS EDITIONS ARE OBSOLETE.
 DRSTS-M Overprint 1, 1 Nov 80

PS--IF YOUR OUTFIT WANTS TO KNOW ABOUT YOUR RECOMMENDATION MAKE A CARBON COPY OF THIS AND GIVE IT TO YOUR HEADQUARTERS

TEAR ALONG PERFORATED LINE

1 Nov 80

FILL IN YOUR
UNITS ADDRESS



FOLD BACK

DEPARTMENT OF THE ARMY

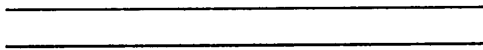

OFFICIAL BUSINESS

COMMANDER
U.S. ARMY AVIATION AND TROOP COMMAND
ATTN: AMSAT-I-MTS
4300 GOODFELLOW BOULEVARD
ST. LOUIS, MO 63120-1798

TEAR ALONG PERFORATED LINE

RECOMMENDED CHANGES TO EQUIPMENT TECHNICAL PUBLICATIONS



THEN... JOT DOWN THE DOPE ABOUT IT ON THIS FORM. CAREFULLY TEAR IT OUT. FOLD IT AND DROP IT IN THE MAIL.

SOMETHING WRONG WITH THIS PUBLICATION?

FROM: (PRINT YOUR UNIT'S COMPLETE ADDRESS)

DATE SENT

PUBLICATION NUMBER

TM 10-4330-236-13&P

PUBLICATION DATE

13 MARCH 1993

PUBLICATION TITLE OPERATOR, UNIT AND DIRECT SUPPORT RPSTL FILTER SEPARATOR, LIQUID FUEL

BE EXACT PIN-POINT WHERE IT IS

PAGE NO	PARA-GRAPH	FIGURE NO	TABLE NO

IN THIS SPACE TELL WHAT IS WRONG AND WHAT SHOULD BE DONE ABOUT IT:

PRINTED NAME, GRADE OR TITLE, AND TELEPHONE NUMBER

SIGN HERE

DA FORM 2028-2
1 JUL 79

PREVIOUS EDITIONS ARE OBSOLETE.
DRSTS-M Overprint 2, 1 Nov 80.

PS--IF YOUR OUTFIT WANTS TO KNOW ABOUT YOUR RECOMMENDATION MAKE A CARBON COPY OF THIS AND GIVE IT TO YOUR HEADQUARTERS

TEAR ALONG PERFORATED LINE

1 Nov 80

FILL IN YOUR
UNITS ADDRESS



FOLD BACK

DEPARTMENT OF THE ARMY

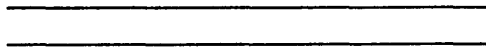

OFFICIAL BUSINESS

COMMANDER
U.S. ARMY AVIATION AND TROOP COMMAND
ATTN: AMSAT-I-MTS
4300 GOODFELLOW BOULEVARD
ST. LOUIS, MO 63120-1798

TEAR ALONG PERFORATED LINE

RECOMMENDED CHANGES TO EQUIPMENT TECHNICAL PUBLICATIONS

SOMETHING WRONG WITH THIS PUBLICATION?



THEN... JOT DOWN THE DOPE ABOUT IT ON THIS FORM. CAREFULLY TEAR IT OUT. FOLD IT AND DROP IT IN THE MAIL!

FROM: (PRINT YOUR UNIT'S COMPLETE ADDRESS)

DATE SENT

PUBLICATION NUMBER

TM 10-4330-236-13&P

PUBLICATION DATE

31 MARCH 1993

PUBLICATION TITLE OPERATOR, UNIT AND DIRECT SUPPORT RPSTL FILTER SEPARATOR, LIQUID FUEL

BE EXACT PIN-POINT WHERE IT IS

PAGE NO	PARA-GRAPH	FIGURE NO	TABLE NO

IN THIS SPACE TELL WHAT IS WRONG AND WHAT SHOULD BE DONE ABOUT IT:

PRINTED NAME, GRADE OR TITLE, AND TELEPHONE NUMBER

SIGN HERE

TEAR ALONG PERFORATED LINE

1 Nov 80

FILL IN YOUR
UNITS ADDRESS



FOLD BACK

DEPARTMENT OF THE ARMY

OFFICIAL BUSINESS

COMMANDER
U.S. ARMY AVIATION AND TROOP COMMAND
ATTN: AMSAT-I-MTS
4300 GOODFELLOW BOULEVARD
ST. LOUIS, MO 63120-1798

TEAR ALONG PERFORATED LINE

RECOMMENDED CHANGES TO EQUIPMENT TECHNICAL PUBLICATIONS



SOMETHING WRONG WITH THIS PUBLICATION?

THEN... JOT DOWN THE DOPE ABOUT IT ON THIS FORM. CAREFULLY TEAR IT OUT. FOLD IT AND DROP IT IN THE MAIL!

FROM: (PRINT YOUR UNIT'S COMPLETE ADDRESS)

DATE SENT

PUBLICATION NUMBER

TM 10-4330-236-13&P

PUBLICATION DATE

31 MARCH 1993

PUBLICATION TITLE OPERATOR, UNIT AND DIRECT SUPPORT RPSTL FILTER SEPARATOR, LIQUID FUEL

BE EXACT PIN-POINT WHERE IT IS

PAGE NO	PARA-GRAPH	FIGURE NO	TABLE NO
---------	------------	-----------	----------

IN THIS SPACE TELL WHAT IS WRONG AND WHAT SHOULD BE DONE ABOUT IT:

TEAR ALONG PERFORATED LINE

PRINTED NAME, GRADE OR TITLE, AND TELEPHONE NUMBER

SIGN HERE

DA FORM 2028-2 1 JUL 79

PREVIOUS EDITIONS ARE OBSOLETE.
DRSTS-M Overprint 2, 1 Nov 80.

P.S.--IF YOUR OUTFIT WANTS TO KNOW ABOUT YOUR RECOMMENDATION MAKE A CARBON COPY OF THIS AND GIVE IT TO YOUR HEADQUARTERS.

FILL IN YOUR
UNITS ADDRESS



FOLD BACK

DEPARTMENT OF THE ARMY

OFFICIAL BUSINESS

COMMANDER
U.S. ARMY AVIATION AND TROOP COMMAND
ATTN: AMSAT-I-MTS
4300 GOODFELLOW BOULEVARD
ST. LOUIS, MO 63120-1798

TEAR ALONG PERFORATED LINE

The Metric System and Equivalents

Linear Measure

1 centimeter = 10 millimeters = .39 inch
 1 decimeter = 10 centimeters = 3.94 inches
 1 meter = 10 decimeters = 39.37 inches
 1 dekameter = 10 meters = 32.8 feet
 1 hectometer = 10 dekameters = 328.08 feet
 1 kilometer = 10 hectometers = 3,280.8 feet

Weights

1 centigram = 10 milligrams = .15 grain
 1 decigram = 10 centigrams = 1.54 grains
 1 gram = 10 decigrams = .035 ounce
 1 dekagram = 10 grams = .35 ounce
 1 hectogram = 10 dekagrams = 3.52 ounces
 1 kilogram = 10 hectograms = 2.2 pounds
 1 quintal = 100 kilograms = 220.46 pounds
 1 metric ton = 10 quintals = 1.1 short tons

Liquid Measure

1 centiliter = 10 milliliters = .34 fl. ounce
 1 deciliter = 10 centiliters = 3.38 fl. ounces
 1 liter = 10 deciliters = 33.81 fl. ounces
 1 dekaliter = 10 liters = 2.64 gallons
 1 hectoliter = 10 dekaliters = 26.42 gallons
 1 kiloliter = 10 hectoliters = 264.18 gallons

Square Measure

1 sq. centimeter = 100 sq. millimeters = .155 sq. inch
 1 sq. decimeter = 100 sq. centimeters = 15.5 sq. inches
 1 sq. meter (centare) = 100 sq. decimeters = 10.76 sq. feet
 1 sq. dekameter (are) = 100 sq. meters = 1,076.4 sq. feet
 1 sq. hectometer (hectare) = 100 sq. dekameters = 2.47 acres
 1 sq. kilometer = 100 sq. hectometers = .386 sq. mile

Cubic Measure

1 cu. centimeter = 1000 cu. millimeters = .06 cu. inch
 1 cu. decimeter = 1000 cu. centimeters = 61.02 cu. inches
 1 cu. meter = 1000 cu. decimeters = 35.31 cu. feet

Approximate Conversion Factors

To change	To	Multiply by	To change	To	Multiply by
inches	centimeters	2.540	ounce-inches	newton-meters	.007062
feet	meters	.305	centimeters	inches	.394
yards	meters	.914	meters	feet	3.280
miles	kilometers	1.609	meters	yards	1.094
square inches	square centimeters	6.451	kilometers	miles	.621
square feet	square meters	.093	square centimeters	square inches	.155
square yards	square meters	.836	square meters	square feet	10.764
square miles	square kilometers	2.590	square meters	square yards	1.196
acres	square hectometers	.405	square kilometers	square miles	.386
cubic feet	cubic meters	.028	square hectometers	acres	2.471
cubic yards	cubic meters	.765	cubic meters	cubic feet	35.315
fluid ounces	milliliters	29.573	cubic meters	cubic yards	1.308
pints	liters	.473	milliliters	fluid ounces	.034
quarts	liters	.946	liters	pints	2.113
gallons	liters	3.785	liters	quarts	1.057
ounces	grams	28.349	liters	gallons	.264
pounds	kilograms	.454	grams	ounces	.035
short tons	metric tons	.907	kilograms	pounds	2.205
pound-feet	newton-meters	1.356	metric tons	short tons	1.102
pound-inches	newton-meters	.11296			

Temperature (Exact)

°F	Fahrenheit temperature	5/9 (after subtracting 32)	Celsius temperature	°C
----	------------------------	----------------------------	---------------------	----

